



Index of Contents

Engine Documentation M 32 C





Original operating instruction	1
Maintenance	2
Technical Engine Data	3
Operating Media	4
Tool Catalogue	5
Spare Parts Catalogue	6
Control and Monitoring	7
External Documentation (Subsupplier Documentation)	8



Original operating instruction

9 M 32 C

Engine No.	39190	Record No.	261236
	39191		





Engine configuration

Engine type:	M 32 C	
Number of cylinders:	9	
Rating:	4500 kW, 600 rpm (name plate rating)	
Fuel grade:	Heavy fuel oil	<input type="checkbox"/>
	Distillate	<input checked="" type="checkbox"/>
	Gas	<input type="checkbox"/>
	Crude Oil	<input type="checkbox"/>
Rotation direction:	Counterclockwise	<input type="checkbox"/>
	Clockwise	<input checked="" type="checkbox"/>
Turbocharging:	Constant charging	<input checked="" type="checkbox"/>
	Pulse charging	<input type="checkbox"/>
FCT:	Yes <input type="checkbox"/>	no <input checked="" type="checkbox"/>
CCR:	Yes <input type="checkbox"/>	no <input checked="" type="checkbox"/>
Application:	Main marine engine, propeller propulsion	<input checked="" type="checkbox"/>
	Main marine engine, diesel-electric propulsion	<input type="checkbox"/>
	Auxiliary marine diesel, generator drive	<input type="checkbox"/>
	Power Plant, generator drive	<input type="checkbox"/>
	Power Plant, water pump drive	<input type="checkbox"/>
	Gas compressor	<input type="checkbox"/>
Piston skirt:	Steel <input checked="" type="checkbox"/>	Casting <input type="checkbox"/>
Turbocharger mounting:	Drive end	<input type="checkbox"/>
	Anti-drive end	<input checked="" type="checkbox"/>
Emission directive:	IMO II	



Table of Contents

M32C

1	General	8
1.1	Observe protection notice in accordance with DIN ISO 16016	8
1.2	Foreword	9
1.3	Warning Notices	10
1.4	Definition of Symbols	12
1.5	Copyright	14
1.6	Warranty	15
1.7	Obligations of the Operator	16
1.8	Exclusion of Liability	17
1.9	Manufacturer's Address	18
1.10	Introduction	19
1.10.1	General	19
1.10.2	Basic Notes on Engine Operation Relating to the Service Life of Combustion Chamber Components	21
1.10.3	Maintenance and Monitoring of Operating Media	21
1.10.4	Monitoring of the Operating Conditions	23
2	Safety	25
2.1	Intended Use	25
2.2	Danger in Case of Non-Observance of Warning Notices	25
2.3	Personnel Requirements	26
2.4	Personal protective equipment	27
2.5	Safety Notes	28
2.6	Safety Devices	29
2.6.1	General	29
2.6.2	Safety Devices on the Diesel Engine	30
2.7	Safety Notes on Maintenance and Troubleshooting	31
2.7.1	General	31
2.7.2	Electrical/Electronic Devices	32
2.7.3	Electro Welding	33
2.7.4	Check According to the Ordinance on Industrial Safety and Health	34
2.8	Noise Measurement	35



Table of Contents

M32C

3	Structure and Function	36
3.1	Overview	36
3.2	Functional Description	37
3.3	Engine Arrangement	38
3.3.1	Foundation of the Ship	38
3.3.2	Maintenance Platforms (optional)	38
3.4	Description of Assemblies	39
3.4.1	Engine Block	39
3.4.2	Main Running Gear	39
3.4.3	Engine Timing	39
3.4.4	Control	39
3.4.5	Turbocharging Group	40
3.4.6	Barring Device	40
3.5	System Description	41
3.5.1	Fuel System	41
3.5.2	Lubricating Oil System	41
3.5.3	Cooling Water System	41
3.5.4	Starting Air System	41
3.5.5	Exhaust System	41
3.6	Safety Devices	42
3.6.1	Engine Safety System	42
3.6.2	Oil Mist Detector (Crankcase Monitoring)	42
3.6.3	Emergency Stop Lever	42
3.6.4	Emergency Stop Push-Button	42
3.6.5	Stop Cylinder	42
3.6.6	Reducing Unit	43
3.6.7	Crankcase Door with Explosion Relief Valve	43
3.6.8	Valve Covers	43
3.6.9	Railings on Maintenance Galleries and Stairs	43
3.6.10	SOLAS Protective Devices	43
3.6.11	Flywheel Guard	43



Table of Contents

M32C

3.7	Control Elements and Displays	44
3.7.1	General	44
3.7.2	Control Panel	44
3.8	Operating Modes	45
3.8.1	General	45
3.9	Nameplate	46
3.10	Scope of Delivery	47
3.10.1	Documentation	47
3.10.2	Accessories	47
3.10.3	Tools	47
3.10.4	Spare Parts and Class Required Parts	47
4	Transportation and Packaging	48
4.1	Safety Notes	48
4.2	Transport Inspection	49
4.3	Handling during Transportation	50
4.3.1	Centre of Gravity and Engine Lifting Points	50
4.3.2	Transportation of Pallets	50
4.4	Unpacking and Loading	51
4.5	Disposal of Packaging Materials	52
4.6	Stability Requirements	53
4.7	Storage of Packing Pieces	54
5	Storage and Preservation	55
5.1	Storage - Measures in Case of Risk of Frost	55
5.2	Preservation - General	56
5.2.1	Light Preservation	56
5.2.2	Heavy-Duty Preservation	56
5.2.3	Packaging/Storage	57
5.2.4	Depreservation	57



Table of Contents

M32C

5.3	Light Preservation (Short-Term Preservation)	58
5.3.1	Engine Preservation Measures	58
5.4	Heavy-Duty Preservation (Long-Term Preservation)	61
5.4.1	Engine Preservation Measures	61
5.4.2	Preservation Measures for Accessories and Tools	63
5.5	Depreservation	64
5.5.1	Depreservation Measures	64
6	Commissioning	66
6.1	Safety Notes	66
6.2	Personnel Qualification	69
6.3	Running-in Instructions	70
6.4	Fuel System	71
6.5	Lubricating Oil System	72
6.6	Cooling Water System	73
6.7	Starting Air System	74
6.8	General Functional Check	75
6.9	Commissioning	76
6.9.1	Putting into Service / Starting	76
6.9.2	Loading during Warming up of a Main Engine	77
7	Regulations for Distillate Fuel Operation	79
7.1	Fuel System	79
7.1.1	Maintenance and Monitoring	79
7.2	Lubricating Oil System	86
7.2.1	Maintenance	87
7.2.2	Lubricating Oil Cleaning	87
7.2.3	Oil Level Check	87
7.2.4	Lubricating Oil System	87
7.2.5	Prelubrication LP2 (Standby/Prelubrication Pump)	89
7.2.6	Functional Test of the Attached Pressure Pump LP1	89
7.2.7	Automatic Filter LF2	89
7.2.8	Duplex Fine Filter LF1 (Indicator)	91
7.2.9	Suction Strainer LF4	91

8	Operational Monitoring	92
8.1	Operation at Low Intake Air Temperatures	92
8.2	Exhaust System/Firing Pressures	93
8.3	Exhaust System - Turbocharging	94
8.3.1	Exhaust Temperatures, General	94
8.3.2	Single-Pipe Exhaust Manifold	94
8.3.3	Permissible Exhaust Temperatures	95
8.3.4	Firing Pressure	96
8.3.5	Firing Pressure Indication	96
8.3.6	Turbocharger: Compressor/ Turbine Cleaning	97
8.3.7	Charge Air Cooler	97
8.4	Turbocharger: Compressor Side	98
8.4.1	Foreword	98
8.4.2	Cleaning Principle	99
8.4.3	Compressor Side - Turbocharger Cleaning Parameters	101
8.5	Changing the Type of Fuel	102
8.5.1	Changeover from Distillate Fuel to Heavy Fuel	102
8.5.2	Changeover from Heavy Fuel to Distillate Fuel	102
8.6	Lubricating Oil System	104
8.7	Cooling Water System	105
8.7.1	Adjustment Instructions for Cooling Water Pressure (Start of Standby Pump, Alarm, and Emergency Stop)	106
8.8	Starting Air System	110
9	Resumption of Engine Operation after a Short Interval	111
10	Operational Disturbances	112
10.1	Operational Disturbances - General	112
10.2	Emergency Stop Safety Devices	113
10.2.1	Actions that Must be Performed after a Safety Emergency Stop*	113
10.2.2	Type of Emergency Stop:	113
10.3	Oil Mist Alarm	118
10.3.1	Checks after an engine stop due to oil mist alarm	118



11	Troubleshooting	121
11.1	Safety Notes	121
11.1.1	Personal Prerequisites	121
11.1.2	Preparations for Troubleshooting	122
11.1.3	Measures before Restarting after Disturbances	123
11.2	General Information about Troubleshooting	124
11.3	Disturbances and Troubleshooting	125
11.3.1	Engine does not start at all or starts poorly	125
11.3.2	Engine reaches firing speed but does not fire	126
11.3.3	Fuel filter differential pressure too high during starting/prelubrication	128
11.3.4	Engine does not reach full speed and/or power	129
11.3.5	Engine speed is not steady	130
11.3.6	Opaque exhaust gas - engine is emitting soot	131
11.3.7	Exhaust gas is blue	132
11.3.8	Exhaust gas is white	133
12	Emergency Operation	134
12.1	Turbocharger Failure	134
12.2	Operational Misfire	138
12.2.1	Misfire	139
12.2.2	Monitoring of the Flexible Coupling	140



1 General

1.1 Observe protection notice in accordance with DIN ISO 16016

"All documents such as drawings, data, and programs, etc. as well as models, templates, etc. shall remain our exclusive property. They are provided only for the agreed purpose and must not be used for any other purpose. Copies or other reproductions including storage, processing or distribution by using electronic systems may only be made for the agreed purpose. Neither originals nor copies may be handed over to third parties or be made available in any other form.

All rights reserved in the event of the grant of a patent, utility model or design.

Offenders will be liable for damages."

Caterpillar Motoren GmbH & Co. KG



1.2 Foreword

These operating instructions are an essential aid for successful and safe operation of the diesel engine. They include important notes on how to operate the diesel engine safely, properly, and economically. Compliance with these operating instructions will help to avoid risks, reduce repair costs and downtime, and increase the reliability and service life of the engine.

All figures and drawings in these operating instructions are for general illustration only.

The operating instructions must be available at the diesel engine at all times. They are to be read and applied by every person carrying out work on the engine and/or operating the engine.

This includes (without limitation):

- Operation
- Troubleshooting
- Care
- Servicing (maintenance, inspection, repair) and/or
- Transport

1.3 Warning Notices

In the present operating instructions the following warning notices are used:



A warning notice of this risk level signals the threat of a dangerous situation.
 If the dangerous situation is not prevented, it will lead to death or serious injury.
 Follow the instructions in this warning notice to prevent the risk of death or serious injury to persons.



A warning notice of this risk level signals a potentially dangerous situation.
 If the dangerous situation is not prevented, this could lead to death or serious injury to persons.
 Follow the instructions in this warning notice to prevent the possible risk of death or serious injury to persons.

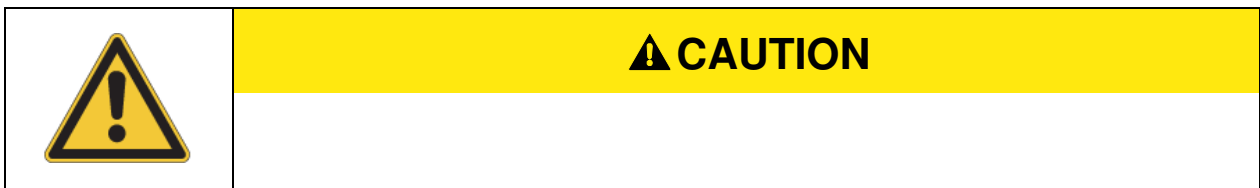

A warning notice of this risk level signals a potentially dangerous situation.
 If the dangerous situation is not prevented, this could lead to minor or moderate injury.
 Follow the instructions in this warning notice to prevent injury to persons.

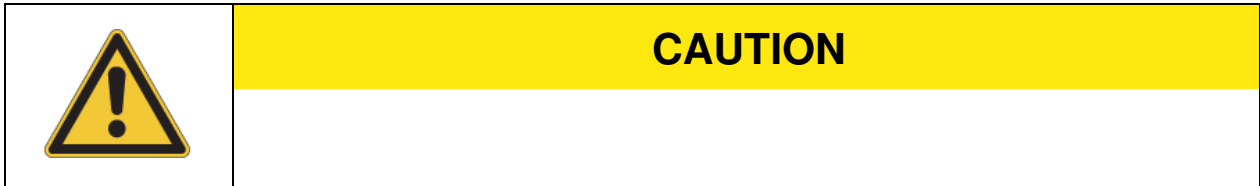

or

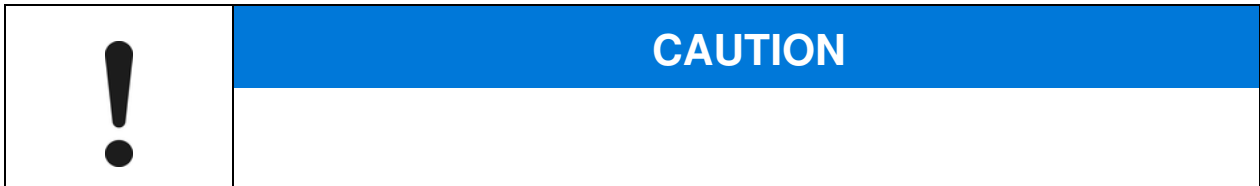



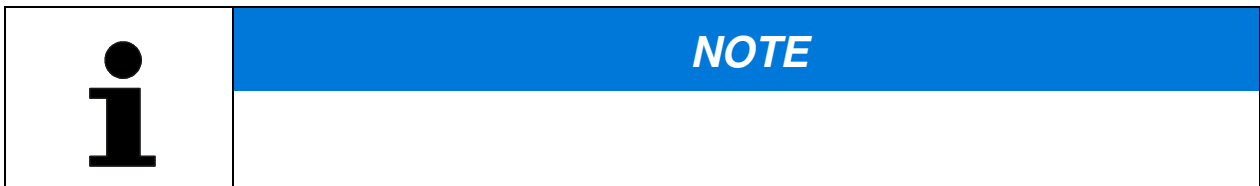





A warning notice of this risk level signals possible damage to property.
If the situation is not prevented, this could lead to damage to property.
Follow the instructions in this warning notice to prevent damage to property.





A note identifies additional information that facilitates the handling of the engine.

1.4 Definition of Symbols

Warning notices are indicated by symbols in these instructions.
 In the present operating instructions the following symbols are used:

Symbol	Meaning
	General warning notice
	Danger - electric current
	Risk of explosion
	Note - possible damage to health
	Risk of burns on hot objects or surfaces
	Danger - cold substances, objects or surfaces
	Danger - falling objects
	Danger - tilting objects

Symbol	Meaning
	Risk of slipping
	Environmental risks
	Danger - poisonous substances
	Danger - combustible substances
	Danger - pipes or components under pressure
	Risk of injuries to hands
	Risk of crushing
	Risk of damage to property
	General information



1.5 Copyright

These operating instructions are to be treated confidentially. They may only be used by the authorized group of persons. They may only be made available to third parties with the written agreement of Caterpillar Motoren GmbH & Co. KG.

All documents are protected under copyright law.

Dissemination and reproduction of documents or parts of documents, as well as the application and communication of their contents is prohibited, unless express permission is obtained. Infringements are punishable and liable to damages.

We reserve all rights to exercise industrial property rights.

1.6 Warranty

Please read these operating instructions carefully before commissioning the diesel engine.

The manufacturer accepts no liability for damage and malfunction resulting from any failure to observe the operating instructions.

The operator is to supplement the operating instructions with guidelines based on existing national accident prevention and environmental protection regulations, including information on the obligation to monitor and report any operational anomalies observed, e.g. with regard to work organization, work processes and employed personnel.

In addition to the operating instructions and the binding accident prevention regulations applicable in the country and location of use, the recognized technical regulations for safe, professional working must also be observed.

The warranty shall lapse in cases of:

- Improper use
- Use of inadmissible operating resources
- Faulty connection
- Preliminary work that is not included in the scope of supplies and services
- Failure to use original spare parts and accessories
- Retrofits, if they have not been approved by Caterpillar Motoren GmbH & Co. KG
- Failure to perform required maintenance work

1.7 Obligations of the Operator

The diesel engine may be a source of danger if operated in an improper manner, or while being in an improper condition.

The operator is obliged to operate the engine only in proper condition. Hazard areas between engines and customer equipment are to be secured by the operator.

The operator must identify and instruct responsible persons:

- Only employ trained or instructed personnel.
- Clearly define the responsibilities of the personnel for operation, setting-up, servicing, repair.
- Regularly check if the personnel is working with due safety and risk awareness whilst observing the operating instructions.
- Before beginning work, the personnel assigned to work on the machine must have read and understood the operating instructions, in particular the "Safety" chapter, as well as the applicable regulations.
- Keep the operating instructions and applicable regulations accessible to the operating and servicing personnel.
- Determine responsibility for the engine and reject all third party instructions that are in breach of safety regulations.

In addition to the operating instructions, observe and follow general legal and other binding accident prevention and environmental protection regulations.

1.8 Exclusion of Liability

All of the technical information, data and notes regarding operation contained in these operating instructions comply with the state of the art on going to press and have been compiled in good faith, in accordance with our prior experience and knowledge.

We reserve the right to make technical modifications in line with further development of the system dealt with in these operating instructions. No claims can be derived from the specifications, illustrations, and descriptions contained in these operating instructions.

We accept no liability for damage and malfunction resulting from operating errors, non-observance of these operating instructions or improper repairs. We expressly point out that only original spare parts and accessories approved by us may be used. This also applies to components of other manufacturers that are used.

The installation and use of non-approved spare parts and accessories and any unauthorized conversions and modifications are not permitted for safety reasons and the liability of Caterpillar Motoren GmbH & Co. KG for any resulting damages is excluded.

Caterpillar Motoren GmbH & Co. KG is liable for any errors or failures on our part, excluding any further claims, within the framework of the warranty obligations entered into in the contract. Claims for damages, regardless of their legal basis, are excluded.

Translations are made to the best knowledge. We cannot accept liability for translation errors, even if the translation was carried out by us or on our behalf. Only the original text shall be binding.

The text and graphic representations do not definitively represent the delivery scope or a possible spare parts order. The drawings and graphics are not to scale.



M20/M25/M32/M43

1.9 Manufacturer's Address

Caterpillar Motoren GmbH & Co. KG

Falckensteiner Str. 2

D-24159 Kiel

P.O. Box

D-24157 Kiel

Tel.: +49 (0) 431 3995-01

Fax: +49 (0) 431 3995-2010

Email: info@CAT.com

Internet:

- <http://www.marine.cat.com>

1.10 Introduction

1.10.1 General

	NOTE
	<p>These operating instructions include notes on commissioning, on how to ensure reliable operation, and on measures to be taken in the event of longer periods of standstill until the engine is put into service again.</p>

Regarding the operating data indicated in these operating instructions, please bear in mind the following:

Due to specific requirements the engine power may have been blocked so that full load cannot be reached. According to DIN ISO 3046 we, therefore, make a distinction between:

- Maximum continuous rating
(the maximum permissible power output for this engine type)
- Rated power
(the power indicated for the engine on the acceptance test record)
- Fuel stop power
(the power output as limited by blocking).

Unless indicated otherwise, we always refer to the maximum continuous rating, which, if unknown to the operator, is to be enquired of the manufacturer.

The power is limited by blocking the fuel racks during the test bed run at rated power and speed. Deviations, if any, are indicated on the acceptance test record, **engine documentation, chapter "Technical Data"**.

	NOTE
	<p>When using heavier fuel grades and in connection with the specific density of the fuel, rated power of the engine will be reached at a fuel rack position that is accordingly lower than compared to MDO operation.</p> <p>The fuel racks must then be blocked at a lower index, particularly in case of a changeover to fuel of significantly higher density (as is the case when changing over from distillate fuel to heavy fuel). Such a change regarding the fuel rack blocking may only be carried out by authorized Caterpillar personnel.</p>

	<p style="text-align: center;">NOTE</p> <p>The operating personnel is to work with the necessary care and observe the safety notes. The existing protection and safety devices must not be removed nor changed. Any change or damage that is identified must be reported to the responsible person. Changes to safety devices in special cases may only be carried out by authorized Caterpillar personnel.</p>
---	--

Initial commissioning will be carried out by authorized professionals.

Clarify any detail questions on site based on the operating instructions. Note down any explanations in these instructions. As a basic rule, capture all data and work that is important for the engine in an engine room log book.

Observe the data and recommendations in the operating instructions together with the maintenance measures recommended by us. These are the prerequisite for a long service life with a constantly high economy of the engine plant.

After every cleaning of the engine with fat dissolving detergents all bare metal parts must be slightly protected again with an oil film.

Special care must be taken to ensure that all bearing points affected by the cleaning are thoroughly lubricated afterwards.

1.10.2 Basic Notes on Engine Operation Relating to the Service Life of Combustion Chamber Components

The operating conditions of the engine are of vital importance to the service life of highly loaded combustion chamber components such as inlet and exhaust valves, pistons, and liners. These, however, can be influenced to a very large extent by the operator of the plant.

In the following some instructions will be provided for the operator on how to increase the service life of these components and save maintenance and operating costs.

1.10.3 Maintenance and Monitoring of Operating Media

Fuel

Fuels with poor ignition qualities will normally lead to increased piston and valve burn due to the formation of fuel deposits that eventually burn or smolder on these components. In extreme cases this may even result in valve burnout and piston burn. Past experience has shown that this may already be caused by one bunkering (charge), thus considerably decreasing the expected or scheduled maintenance interval (TBO). In the worst case vanadium may act as a catalyst to the formation of acid, i.e. strong acids will be formed from constituents of the fuel (such as sulphur) beyond the normal extent.

Therefore, an extended analysis is to be requested from the analyzing laboratory at regular intervals or whenever there is a suspicion of poor fuel quality.

The analysis is to cover the following:

- Content of aromatic compounds and asphaltenes in the fuel
- Nitrogen content
- Vanadium content
- Sodium content
- Oxygen content
- Calcium content
- Phosphor content
- Zinc content

Upon receipt of the analysis consult the Caterpillar service station responsible for your support.

Lubricating oil

As regards the lubricating oil maintenance it is of particular importance to ensure correct separation and filtration and keep an eye on the operating values of the oil. Generally, we recommend to have the lubricating oil analyzed at regular intervals by a laboratory.

Important characteristics of the lubricating oil are:

- **Viscosity:** For the formation of a corresponding lubricating wedge a correct viscosity is of vital importance. In order to avoid damage to the engine, the viscosity must range within the specified limits.
- **TBN (Total Base Number):** Characterizes the neutralizing capability of the oil. Through the combustion air and the fuel acid formers are introduced into the engine. These forming acids must be neutralized in order to protect the engine components against corrosive attack.
- **Water content:** A high percentage of water in the oil has a corrosive effect. Furthermore, steam bubbles may form under certain pressure and temperature conditions (e.g. in bearings), disrupt the lubricating film and thus cause damage.
- **Percentages of individual chemical elements:** Especially important is the vanadium content. Depending on the measuring method the vanadium content can be indicative of a rising percentage of heavy fuel in the lubricating oil. A high percentage of heavy fuel in the engine lubricating oil may particularly affect piston cooling, which in turn may lead to piston burn.

1.10.4 Monitoring of the Operating Conditions

Injection system

We are particularly emphasizing the importance of monitoring the fuel for correct injection viscosity.

The connection between the viscosity of the fuel and its temperature is used for controlling the injection viscosity. To this end, the viscosimeter is continually capturing the current viscosity. In case of discrepancies between the current and the preset value the viscosimeter will transmit a signal to the fuel preheater which in turn regulates the temperature of the fuel. This will be continued until there is no more discrepancy between the current and the preset viscosity value. Low temperatures of the fuel always lead to higher viscosity and vice versa.

Due to this control principle it is very important to avoid long distances between viscosimeter and the injection pump on the engine so as to ensure that the adjusted fuel temperature actually reaches the engine.

Problems in case of wrongly adjusted injection viscosity:

Low viscosity:

- Seizure of the injection pumps due to decreased lubrication of the pump plunger (especially in case of changeover to gas oil operation and formation of steam bubbles due to excessive temperature and the resulting excess consumption)

High viscosity:

- Poor atomization of the fuel, which may lead to severe formation of soot due to poor combustion, high mechanical load on the entire injection system and combustion chamber components: Cam follower roller, cam follower, injection pump, fuel injector, piston crown and potential contamination of the turbocharger.

Turbocharging

The turbocharger is one of the most sensitive components of the engine. The efficiency of the turbocharger essentially depends on its degree of contamination, which determines whether the individual cylinders are supplied with a sufficient amount of air. Consequences of a poorly performing turbocharger can be:

- Drop in engine power
- Rising fuel consumption
- High temperatures of the combustion chamber components, which may significantly reduce service life, particularly of the combustion chamber components.

Engine room ventilation

Prerequisite for proper function of the turbocharger and thus a proper air supply to the engine is a good engine room ventilation. Especially during the hot summer months or in warm regions of the world particular attention should be given to this aspect.

	CAUTION
	<p>Property damage due to overheating.</p> <p>Failure to take proper precautions may cause damage to the engine due to overheating.</p> <p>Ensure maximum engine room ventilation.</p>

Make sure that all available engine room ventilators are running and all air ducts are fully open. Furthermore, a positive effect can be achieved by aligning the fins of the louvers so that the air flow reaches the turbocharger in an optimal way. An indicator of sufficient ventilation by a given engine room ventilation system is a slight overpressure in the engine room.

2 Safety

2.1 Intended Use

	⚠ WARNING
<p>Danger due to non-intended use.</p> <p>The diesel engine may be a source of danger if operated not in compliance with the intended use and/or being used otherwise.</p> <ul style="list-style-type: none"> > Use the diesel engine for its intended purpose only. > Observe the procedures described in the operating instructions. 	

The intended use is the purpose agreed upon with Caterpillar in the Project Approval Request. Before deviating from the agreed purpose, it is absolutely required to contact Caterpillar Motoren GmbH & Co. KG.

The manufacturer/supplier accepts no liability for damage resulting from non-intended use. The risk exclusively rests with the user/operator.

2.2 Danger in Case of Non-Observance of Warning Notices

Failure to observe the relevant warning notices when carrying out any work on the diesel engine creates hazards that may cause damage to health or injuries up to death.

Personnel should stay within the hazard area only for the absolute minimum required for operational reasons.

An operating diesel engine may create hazards to the operator, particularly due to:

- Possible discharge of poisonous liquids or gases under high pressure.
- Contact with rotating components
- Contact with hot surfaces
- Noise exceeding 110 dBa.

Wear personal protective equipment.

2.3 Personnel Requirements

	NOTE
<p>Work on/with the engine may only be carried out by persons who, due to their education and qualification, are authorized to do so. Furthermore, they must have been commissioned to do so by the operator.</p>	

Personnel to be trained, instructed or briefed or personnel receiving general training may only be allowed to work on the engine under the permanent supervision of an experienced person!

Persons who are under the influence of drugs, alcohol or medicines that impair their ability to respond must not be allowed to carry out any work on the engine.

Any connection, setup, maintenance or repair work may only be carried out by trained professionals.

Persons actuating power-operated work equipment are to ensure that neither themselves nor others are put in danger by hazardous movements.

The operator may only assign work on power-operated work equipment involving hazardous movements to persons who are authorized to do so and

- capable of carrying it out independently and safety or,
- following prior instructions, are under the supervision of a person familiar with this work.

This engine may be a source of danger if operated in an improper manner by untrained personnel or used not in compliance with its intended use.

In addition to the operating instructions observe the general legal and other binding regulations for accident prevention and pollution control as well as basic health and safety requirements. The operator has to instruct his personnel accordingly.

2.4 Personal protective equipment

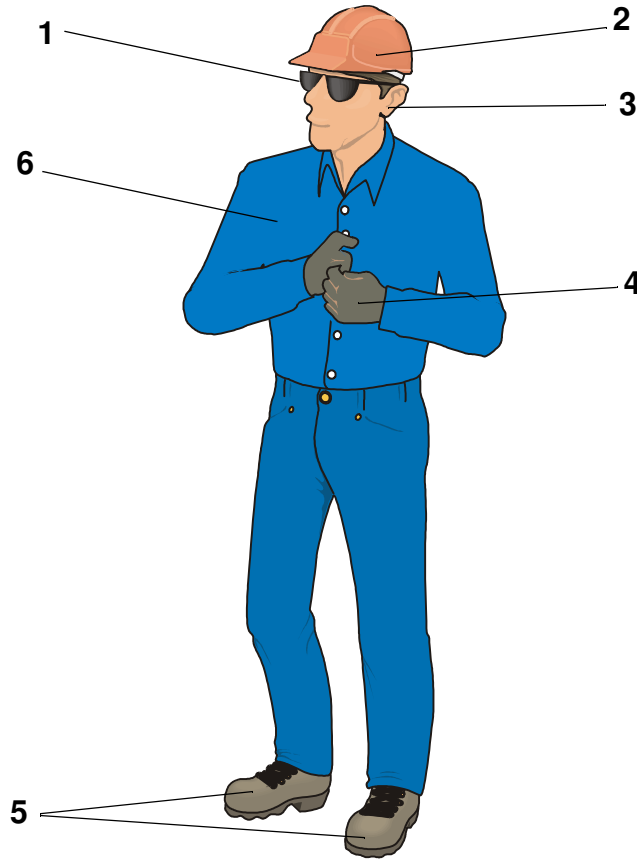

Personal protective equipment	
1 Safety glasses	4 Protective gloves
2 Hard hat	5 Safety shoes
3 Ear protection	6 Tight fitting protective clothing

	⚠ WARNING
<p>Hazard due to engine operation! It is absolutely required to use personal protective equipment! The recommended personal protective equipment is no substitute for caution and care in operating the engine and compliance with the applicable safety regulations. Personnel should stay within the hazard area only for the absolute minimum required for operational reasons.</p>	

2.5 Safety Notes

Observe the following notes for preventing accidents while operating the diesel engine.

- Operate the engine only in proper condition.
- Do not remove or put out of service any safety devices.
- Before commissioning check the engine for defects and deficiencies visible on the outside.
- Immediately notify any changes (including changes in operating behaviour) to the competent authority/person. If necessary, immediately stop and secure the engine.
- Adjustment and/or maintenance work is to be carried out by authorized professionals.
- Replace worn or damaged parts.
- Only use suitable tools.
- After completion of repair work reinstall all protective devices and check them both electrically and mechanically.
- Observe switching on/off procedures, control displays according to the operating instructions.
- Before switching on/starting the engine make sure that nobody can be endangered by the engine.
- The operator has to ensure that the engine is operated only in proper condition and that all applicable safety requirements and regulations are met.
- Keep the operating instructions near the engine so as to be readily available at any moment.
- Non-observance of the safety notes contained in these operating instructions may result in property damage, injuries or even death of persons.

2.6 Safety Devices

2.6.1 General

Check all safety, protective, and locking devices on the engine for safe condition.

Operate the engine only if all safety, protective, and locking devices are in place and functional. The operator as well as the operating personnel are responsible for proper operation of the engine.



NOTE

Warning/danger signs are provided on the engine in order to protect the operating personnel. Observe these signs.

Immediately replace any damaged or illegible warning/danger signs.

2.6.2 Safety Devices on the Diesel Engine

Depending on the respective purchase order the diesel engine is equipped with the following protective devices:

- Engine safety system
- Oil mist detector (crankcase monitoring)
- Emergency stop leber (on the control panel)
- Emergency stop push-button
- Stop cylinder on each injection pump
- Maintenance unit (on the back of the control panel)
- Crankcase door with explosion relief valves
- Valve covers
- SOLAS protective devices such as exhaust pipe cladding, splash protection, etc.
- Flywheel guard

For further information on safety devices please refer to the *operating instructions, chapter "Structure and Function"*.

2.7 Safety Notes on Maintenance and Troubleshooting

2.7.1 General

- Replace hose pipes at regular intervals even if no safety relevant defects can be identified.
- Observe the deadlines that are specified or indicated in the operating instructions for recurring checks/inspections.
- The execution of maintenance measures absolutely requires an appropriate workshop equipment corresponding to the nature of the work.
- Work on electrical equipment of the engine may only be carried out by a specialist electrician or by trained persons under the direction and supervision of a specialist electrician according to the rules of electrical engineering.
- Observe the adjustment, maintenance, and inspection activities and intervals specified by Caterpillar Motoren GmbH & Co. KG including any data on the replacement of parts/part equipment. These activities may only be carried out by authorized professionals.
- Inform the operating personnel before starting any special and maintenance work. Designate a supervising person.
- If required, close off a large area where the engine is being serviced.
- If the engine is completely switched off during maintenance and repair work it must be secured against being switched on again.
- Screwed connections that were loosened during maintenance and repair work are to be retightened according to the specified torques.
- If maintenance and repair work requires the dismantling of safety devices, the safety devices are to be reinstalled and checked immediately after completion of the maintenance and repair work.
- Ensure safe and environmentally compatible disposal of operating media and auxiliary materials as well as replaced parts.
- Ensure sufficient lighting for all work.
- Only original spare parts or spare parts approved by Caterpillar Motoren GmbH & Co. KG may be used.

2.7.2 Electrical/Electronic Devices

	⚠ DANGER
<p>Danger of death due to electricity!</p> <p>There is danger of death when coming in contact with live wires or components.</p> <ul style="list-style-type: none"> > Before carrying out any work on electrical equipment disconnect it from the mains and secure it against being switched on again. > Cover any adjacent live components. 	

Before carrying out any work on electrical equipment switch off the main circuit breaker and secure it by means of a padlock against being switched on again. Additionally, a warning sign is to be provided on the main circuit breaker during the work.

Work on electrical/electronic components/assemblies may only be carried out by specialist electricians according to the rules of electrical engineering.

Important rules of conduct

- Observe class rules if applicable.
- Check the engine regularly. Immediately remedy any identified defects or disturbances. Switch off the engine until the defects are remedied.
- Defects identified on electrical installations/assemblies/operating equipment must be remedied immediately. If there is any acute hazard until then, the engine, assembly or operating equipment must not be used in such defective condition.
- Engine components on which inspection, maintenance and repair work is being carried out must - if specified - be disconnected from the mains. The components thus disconnected from the mains must first be checked for zero potential, then earthed and short-circuited and adjacent live components must be isolated.
- If it is necessary to carry out any work on live components, call in a second person who, in case of an emergency, will operate the main circuit breaker with shunt tripping.

Close off the working area during the work and provide with a warning sign. Use only voltage-insulated tools.

Fuses must not be repaired or bridged. Use only original fuses for the specified current.

2.7.3 Electro Welding

	NOTE
	<p>No electro welding may be carried out on the engine.</p>

If electro welding is carried out on plants or equipment that are mechanically and thus conductively connected with engines the following measures are to be taken:

- Clean the engine of dust and flammable substances.
- Unplug or disconnect any electronic devices on the engine.
- All terminal boxes and systems are to be disconnected from the mains by means of the corresponding circuit breakers.
- Arrange the earth connection of the welding device directly next to the welding point and provide proper contact.

The welding current must not flow via the earth wire or shielding of the electrical equipment.



M20/M25/M32/M43

2.7.4 Check According to the Ordinance on Industrial Safety and Health

In case of combining or installing machines/plants or operating equipment of different manufacturers or suppliers, after re-engineering products supplied by us including interventions on the electrical equipment, the operator must, prior to commissioning, carry out an accurate check according to the current Ordinance on Industrial Safety and Health and the applicable electrical engineering rules.

In case of open questions consult Caterpillar Motoren GmbH & Co. KG.

2.8 Noise Measurement

Measuring conditions:

The measurement was carried out according to DIN 45635-11-KL2 at the manufacturer.

	<div style="background-color: red; color: white; text-align: center; padding: 5px;">⚠ DANGER</div> <p>Danger due to noise.</p> <p>Depending on local conditions there may be a high noise pressure level resulting in noise-induced hearing loss.</p> <p>> In case of increased noise pressure level (>85 dB(A)) wear ear protection.</p>
---	---

3 Structure and Function

3.1 Overview



For the **engine arrangement** an adequate design of the ship's foundation and the maintenance platforms is to be ensured in advance.

An engine plant consists of different assemblies and systems. These include (without limitation):

Engine assemblies

- 1 Engine block
- 2 Main running gear
- 3 Timing gear
- 4 Control
- 5 Turbocharging group
- 6 Barring device
- 7 Control panel
- 8 Safety devices

Systems

- A Fuel system
- B Lubricating oil system
- C Cooling water system
- D Starting air system
- E Exhaust system

3.2 Functional Description

The engine is installed on a frame in the ship's foundation intended for this purpose.

The fuel required for combustion is supplied to the engine by means of a fuel system. In the fuel system the fuel is heated up before combustion. Contaminations such as sludge and water are removed by separation (see *operating instructions, chapter "Regulations for Heavy Fuel Operation", paragraph "Fuel System"* and *engine documentation, chapter "External Documentation"*).

The air which is precompressed in the turbocharger is fed into the respective cylinder of the engine block. There the air is further compressed and thus heated up. Shortly before the piston reaches its upper dead centre the fuel prepared in the fuel system is injected into the cylinder through a nozzle. The fuel evaporates and the steam-air mixture ignites. Due to the combustion the piston is pressed downward. In this movement the piston drives a crankshaft via a connecting rod. The energy of the crankshaft is transmitted via a coupling to a generator, ship propeller or similar. The fuel supply to the individual cylinders is controlled via a camshaft. The camshaft is connected with the crankshaft via a gear train.

For starting the engine is equipped with a starting air system. The corresponding pistons are pressed down one after the other and the engine speed is raised to firing speed. Fuel is injected and the first auto-ignition takes place.

In order to limit the amount of wear and tear to which the rubbing surfaces in the engine are subjected, the engine is equipped with a lubricating oil system.

The heat generated in the engine during the combustion process is carried off by the cooling water system. The engine freshwater cooling system consists of two separate, closed loop circuits.

The HT (high temperature or jacket water) stage provides primarily coolant for engine cooling, it circulates around the upper area of the cylinder liner (cooling water distributor housing) and through the cylinder head. In a secondary function it supports cooling of the LT stage.

The LT (low temperature or aftercooler circuit) stage provides coolant for the combustion air and all connected auxiliary components.

The cooling procedure for both cooling water circuits depends on the engine operation

For Marine Engines the cooling media is mostly seawater.

In power producing engines the cooling water is mostly cooled by radiators.

The exhaust gas generated in the engine is carried off via the exhaust system.

Besides remote control facilities the engine can also be controlled via the control panel.

For inspection and maintenance work the engine is provided with maintenance platforms and a barring device, depending on equipment status. With the barring device the crankshaft can be moved to the desired position when the engine is at a standstill.



3.3 Engine Arrangement

3.3.1 Foundation of the Ship

The ship's foundation is part of the hull and must be designed according to the corresponding classification rules in such a way that it absorbs the static and dynamic load created by the engine. A resilient mounting (as an option) between foundation and engine reduces vibration and noise (structure borne noise).

Design and construction of the foundation for the engine in the ship are the sole responsibility of the shipyard.

3.3.2 Maintenance Platforms (optional)

	<p style="text-align: center;">⚠ WARNING</p> <p>Risk of slipping. Before carrying out assembly work on the maintenance platform pay attention to oil, fuel or water pools and remove them.</p>
	<p style="text-align: center;">⚠ WARNING</p> <p>Danger of collapse and breakage. The maintenance platform may only be subjected to load from persons and assembly tools. Do not put heavy engine components such as pistons, liners, cylinder heads, etc. onto the maintenance platform.</p>

The maintenance platform is fitted to the outside of the engine. This makes it easier to carry out maintenance and inspection work.

Ladders and working platforms are to be manufactured from anti-slip material and secured by means of railings. Access to the maintenance platform is to be provided by the shipyard.

3.4 Description of Assemblies

3.4.1 Engine Block

The engine block consists of torsionally stiff nodular cast iron. The M 32 is available in the following cylinder configurations:

6-, 8- or 9-cylinder in-line engine

12-, 16-cylinder V-engine

The engine can be supplied with a normal or with a deep oil pan.

3.4.2 Main Running Gear

The pistons in the cylinders transmit the reciprocating movement via the connecting rods to the crankshaft. The crankshaft converts the reciprocating movement of the pistons into a rotary movement. The power transmission from the crankshaft takes place via a coupling. Contrary to stationary applications in marine applications there is always a gearbox installed between engine and driving shaft.

The cylinder heads seal the upper end of the combustion chambers. In the cylinder heads the injection nozzles and the inlet and exhaust valves are mounted. Through the injection nozzles the fuel is injected into the combustion chambers of the cylinders. Via the valves the precompressed combustion air is let in and exhaust gas let out respectively.

The cylinder heads are covered by means of valve covers.

3.4.3 Engine Timing

Engine timing takes place via the camshaft which is indirectly driven by the crankshaft. By the rotating camshaft the rocker arms are actuated via the push-rods. The rocker arms open the valves for combustion air and exhaust gas respectively. Return springs close the valves again.

3.4.4 Control

The injection pumps (fuel rack position) are controlled via the control linkage controlled by a governor. Settings and/or changes to settings may only be carried out by personnel authorized by Caterpillar.

3.4.5 Turbocharging Group

In the turbocharger the air required for the combustion process in the combustion chambers of the cylinders is precompressed (charge air).

The turbocharger consists of a turbine and a compressor which are mechanically connected to each other via a shaft. The exhaust gas generated in the cylinder during the combustion process is let out into the exhaust system through the valves in the cylinder head and conveyed to the turbine in the turbocharger. The turbine driven by the exhaust gas in turn drives the compressor via the shaft. The compressor compresses the intake air to charge air and feeds it into the engine.

3.4.6 Barring Device

With the barring device the crankshaft can be moved to the desired position when the engine is at a standstill.

For further information please refer to the documentation of the manufacturer.

3.5 System Description

3.5.1 Fuel System

In the fuel system the fuel for combustion is prepared and fed into the engine. For further information please refer to the documentation of the manufacturer.

3.5.2 Lubricating Oil System

In order to limit the amount of wear and tear to which the rubbing surfaces in the engine are subjected, the engine is equipped with a lubricating oil system. The essential tasks of the lubricating oil are the following:

- Lubrication of the moving parts
- Removal of contamination at the friction points
- Removal of heat
- Lubrication between liner wall and piston ring

3.5.3 Cooling Water System

The cooling water system consists of three circuits.

The first cooling circuit is operated with freshwater. This circuit cools the upper area of the cylinders, the cylinder heads and the HT (high temperature) stage of the charge air cooler.

The second circuit is also operated with freshwater and cools the lubricating oil cooler and the LT (low temperature) stage of the charge air cooler.

The third cooling circuit is operated with seawater. This circuit cools the other two circuits. Due to these different circuits direct contact between seawater and the engine is avoided. This prevents corrosion damage.

For further information please refer to the documentation of the manufacturer.

3.5.4 Starting Air System

During the starting process of the engine air is admitted to the pistons in the cylinders until the engine reaches firing speed.

3.5.5 Exhaust System

The exhaust gas generated in the combustion chambers of the cylinders is let out of the cylinders through the valves in the cylinder heads and carried off via the exhaust system.

3.6 Safety Devices

3.6.1 Engine Safety System

In case of a critical operating condition (e.g. lack of lubricating oil pressure, overspeed, lack of cooling water) the safety system of the engine triggers an automatic engine stop or a power reduction. For this purpose measuring signals of different sensors, pressure and temperature switches of the engine are evaluated.

	<p style="text-align: center;">CAUTION</p> <p>Damage due to defective engine sensor equipment!</p> <p>Defective sensors, pressure and temperature switches may cause significant damage to property.</p> <ul style="list-style-type: none"> > In case of malfunction of individual sensors, pressure and temperature switches these are to be replaced without delay. > Observe the maintenance instructions for the individual sensors, pressure and temperature switches (see <i>operating instructions, chapter "Maintenance"</i>).
---	--

3.6.2 Oil Mist Detector (Crankcase Monitoring)

In crankcases of internal combustion engines oil mist and oil vapour is generated by different factors. In combination with ignition sources (e.g. due to bearing damage) oil mist may lead to crankcase explosion.

The oil mist detector permanently aspirates the oil mist, evaluates it and gives an alarm in case of danger.

3.6.3 Emergency Stop Lever

The emergency stop lever is located on the control panel of the engine. With the emergency stop lever the engine can be shut down completely.

The emergency stop lever acts directly on the fuel rack linkage of the injection pumps and may only be used in emergency cases.

3.6.4 Emergency Stop Push-Button

The stop push-button is located on the control panel of the engine and, if pressed, triggers an immediate engine stop regardless of load and speed conditions.

3.6.5 Stop Cylinder

On each injection pump of the engine a stop cylinder is mounted.

In case of an automatic engine stop the stop cylinders are activated by the safety system and press the control rods of the injection pumps to zero fuel feed.

3.6.6 Reducing Unit

The reducing unit is part of the maintenance unit installed on the back of the control panel. The reducing unit supplies the stop cylinders and the related valves with the required working/control air. Observe the maintenance instructions for the maintenance unit.

3.6.7 Crankcase Door with Explosion Relief Valve

The explosion relief valve reduces in a controlled manner any overpressure that may build up due to deflagration in the crankcase.

3.6.8 Valve Covers

The valve covers are installed on the cylinder heads. The valve covers protect the valves, rocker arms, etc. against damage and contamination. Furthermore, they prevent uncontrolled splashing of the lubricating oil. The valve covers may only be opened when the engine has come to a standstill.

3.6.9 Railings on Maintenance Galleries and Stairs

Depending on the installation, parts of the engine are only accessible from a working platform. The working platforms are secured by means of railings and must be kept in a proper condition.

3.6.10 SOLAS Protective Devices

The SOLAS protective devices include e.g. the exhaust cladding and splash protection. Their proper condition is to be ensured.

3.6.11 Flywheel Guard

The flywheel guard is to be kept in proper condition.

3.7 Control Elements and Displays

3.7.1 General

Control and monitoring of the engine takes place either by means of control elements and displays on the control panel arranged on the engine or indirectly via an external control unit.

In case of disturbances or failure of the external control unit the engine can be operated from the control panel.

3.7.2 Control Panel

The control panel is arranged directly on the engine. The control panel allows to read off i.a. the following information and switch the following functions:

- Exhaust temperature after cylinder
- Turbocharger speed
- Engine speed
- Pressures and temperatures of the operating media
- Start, stop, and emergency stop of the engine
- Changeover switch "Local - Remote"
- Changeover switch "Operation - Repair"
- Emergency stop lever (10)

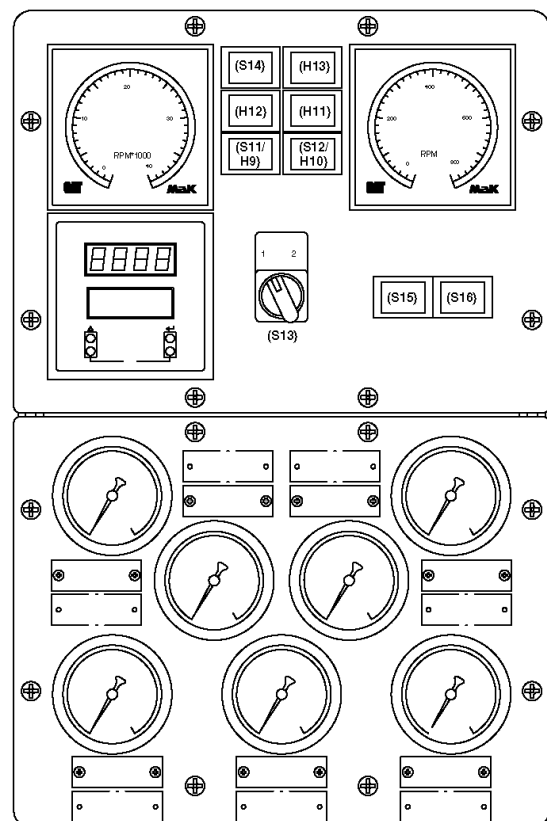
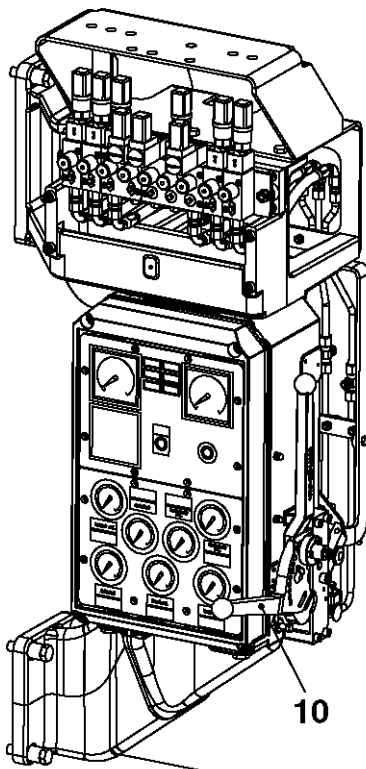

3.8 Operating Modes

3.8.1 General

Basically, the engine is designed for operation on heavy fuel and distillate fuel.



NOTE

Please also refer to *engine documentation, chapter "Operating Media"*

3.9 Nameplate

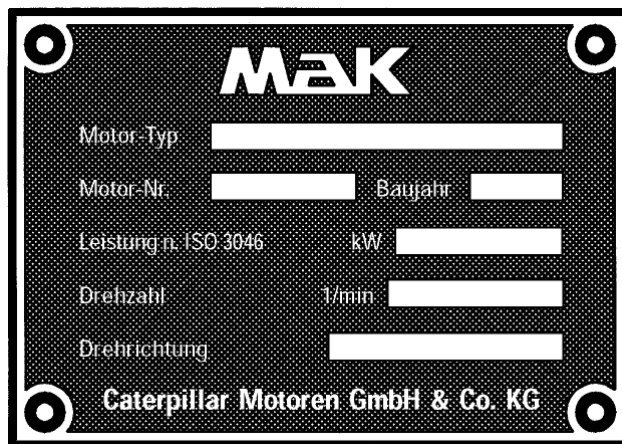

The nameplate is located at the centre of the control side of the engine. It provides the following information:

- Manufacturer
- Engine type
- Engine number
- Year of construction
- Power output
- Engine speed
- Direction of rotation

3.10 Scope of Delivery

In addition to the basic engine the scope of delivery includes the following based on the purchase order:

3.10.1 Documentation

- Operating Instructions
- Maintenance
- Technical Engine Data
- Operating Media
- Steuerung/Regelung
- Tool Catalogue
- Spare Parts Catalogue
- External Documentation (Zulieferdokumentation)

3.10.2 Accessories

3.10.3 Tools

The tools required for maintenance and repair work may be added to the engine as tool kit depending on the order.

3.10.4 Spare Parts and Class Required Parts

Depending on the order diverse spare parts and class required parts may be included in the scope of delivery.

For further Information please refer to *engine documentation, chapter "Spare Parts Catalogue"*.

4 Transportation and Packaging

4.1 Safety Notes

	⚠ WARNING
	<p>Danger of death due to suspended load.</p> <p>When lifting a load there is danger of death due to parts that may fall down or swing in an uncontrolled manner.</p> <ul style="list-style-type: none"> > Never stand under a suspended load. > Observe the specifications regarding the provided lifting points. > Do not sling to projecting machinery parts or eyes of fitted components. Ensure perfect fit of the slings. > Only use approved hoists and slings of sufficient capacity. > Do not use ropes and belts that are cracked superficially or abraded. > Do not attach ropes and belts to sharp edges and corners, do not knot and twist.

	⚠ WARNING
	<p>Falling hazard due to eccentric centre of gravity.</p> <p>Packing pieces may have an eccentric centre of gravity. If incorrectly slinged, the packing piece may tilt and cause lethal injuries.</p> <ul style="list-style-type: none"> > Observe the markings on the packing pieces. > Sling the crane hook so that it is above the centre of gravity. > Carefully lift the load and watch whether the load is tilting. If necessary, change the slinging arrangement.

	CAUTION
	<p>Damage due to improper transportation.</p> <p>Improper transportation may cause significant damage to property.</p> <ul style="list-style-type: none"> > During unloading of packing pieces, delivery and internal transportation proceed with care and observe the symbols and notes on the packaging. > Remove packaging only shortly before assembly.

4.2 Transport Inspection

Check the delivery for completeness and possible transport damage immediately upon receipt.

	NOTE
In case of non-observance of the following instructions for damage cases the insurer may not be liable for damages any more.	

In case of transport damage that is visible on the outside proceed as follows:

- Already in case of a suspected damage acknowledge receipt only under reservation (e.g. on the shipping document) indicating what damage is being assumed.
- If the goods are in containers, make sure that containers and locks or seals are checked by representatives of the shipowners or the carrier. If a container was damaged or locks and seals were broken, are missing or do not correspond to the shipping documents, acknowledge receipt only under reservation indicating the suspected damage and keep any damaged or wrong locks and seals in custody.
- Secure any claims against third parties. Shipowners, other carriers, forwarders, stock keepers, customs and port authorities
 - are to be asked to carry out a joint damage inspection
 - are to be asked to certify the damage
 - are to be held liable in writing and the damage is to be described in detail.

In case of damage visible on the outside this has to take place before acceptance of the goods, in case of damage not visible on the outside this should occur immediately upon discovery.

- Ascertain and keep the time limits for claims.

	NOTE
Claim each defect as soon as identified. Claims for damages can only be raised within the applicable time limits.	

- Take action to mitigate the damage that has occurred and to avoid further damage.
- Immediately consult the average adjustor indicated in the insurance documentation to ascertain the damage and provide advice on how to secure claims for damages against third parties and actions to mitigate the damage.
- Do not alter the condition of the consignment before arrival of the average adjustor unless to the extent required for mitigating and avoiding further damage.
- Immediately notify the claim to the insurer and, in order to accelerate the claim settlement, provide him as soon as possible (latest, however, in a timely manner before expiry of possible preclusion and/or limitation periods for claims against third parties) with complete damage documentation.

4.3 Handling during Transportation

4.3.1 Centre of Gravity and Engine Lifting Points

The engine may only be lifted by means of the handling device provided by Caterpillar Motoren GmbH & Co. KG. This handling device remains the property of Caterpillar Motoren GmbH & Co. KG. It must be returned in perfect condition with carriage prepaid.

For further information regarding appropriate use of the handling device please refer to the operating instructions of the handling device.

	NOTE
<p>For information on centre of gravity, lifting points of the individual assemblies and components please refer to chapter "Maintenance".</p>	

4.3.2 Transportation of Pallets

Pallets must be secured against slipping during transportation.

Transportation of pallets by means of a crane

Packing pieces fastened on pallets can be transported by means of a crane under the following conditions:

- Crane and hoists must be designed for the weight of the packing pieces.
- The operator must be authorized to handle the crane.

Slinging:

1. Sling ropes, belts or multi-point tackles to the pallet according to instructions.
2. Check whether the packing pieces are not damaged by the slings. If necessary, use different slings.
3. Start the transportation.

Transportation of pallets by means of a fork lift

Packing pieces fastened on pallets can be transported by means of a fork lift under the following conditions:

- The fork lift must be designed for the weight of the transport units.
- The driver must be authorized to drive the fork lift.

Picking up and transporting the cargo:

1. Move the fork lift so as to insert its forks between or below the stringers of the pallet.
2. Insert the forks so that they project on the opposite side.
3. Make sure that the pallet cannot tilt in case of eccentric centre of gravity.
4. Lift the packing piece and start the transportation.



M20/M25/M32/M43

4.4 Unpacking and Loading

The individual packing pieces are packaged according to the transport conditions to be expected.

The packaging is to protect the individual components until their assembly against transport damages, corrosion, and other damage. Therefore, do not destroy the packaging and only remove it shortly before assembly.

4.5 Disposal of Packaging Materials

Packaging materials must be disposed of according to the applicable legal provisions and local regulations.

	CAUTION
	<p>Environmental damage due to incorrect disposal.</p> <p>Packaging materials are valuable raw materials and can continue to be used in many cases or reasonably reconditioned and re-cycled.</p> <ul style="list-style-type: none"> > Dispose of packaging materials in an environmentally compatible way. > Follow the locally applicable waste disposal regulations. If necessary, employ a specialized waste disposal company to dispose of packaging materials.

4.6 Stability Requirements

For transportation the engine is installed on a wooden substructure. This will prevent damage to the oil pan during transportation. During transportation the engine is bolted to the substructure. This ensures sufficient stability.



NOTE

The engine must be in upright position and put onto a firm ground so as to rest on it with its entire surface.

4.7 Storage of Packing Pieces

Store the packing pieces under the following conditions:

- Do not store in the open.
- Store dry and dust-free.
- Do not expose to aggressive substances.
- Protect from sunlight.
- Avoid mechanical shocks and damage.
- Storage temperature: 15 to 25 °C.
- Relative humidity: max. 60 %.
- In case of storage longer than 3 months regularly check the general condition of all parts and the packaging. If necessary, refresh or renew the preservation.



NOTE

On the packing pieces there may be notes on storage that exceed the requirements outlined above. These are to be observed accordingly.

5 Storage and Preservation

5.1 Storage - Measures in Case of Risk of Frost

Even when the engine is taken out of service for a short period (without warming device) it is required, in areas where temperatures below freezing point may occur, to use a commercial anti-freeze agent with anti-corrosion effect (see *engine documentation, chapter "Operating Media", paragraph "Cooling Water"*).

If the engine is taken out of service for a longer period and there is a risk of frost, the *operating instructions, chapter "Storage and Preservation", chapters "Light Preservation" and "Heavy-Duty Preservation"* must be observed.

For storage of packing pieces the *operating instructions, chapter "Transportation and Packaging", chapter "Storage of Packing Pieces"* must be observed.

	CAUTION
	<p>Property damage due to low temperatures.</p> <p>Low temperatures may cause property damage on the engine.</p> <ul style="list-style-type: none"> > The concentration level of the anti-freeze agent is to be chosen in such a way that a sufficient freeze protection is ensured.

Contrary to anti-corrosion emulsions, the chemical corrosion preventative used in the cooling water can be mixed well with commercial anti-freeze agents.

	NOTE
	<p>Prior to use, enquire the exact range of application of the corrosion preventative from the manufacturer of the corrosion preventative.</p>

5.2 Preservation - General

In case of standstill times in excess of 4 weeks the engine must be preserved. The extent of these measures is determined by climatic conditions and duration of storage.

Durability and effectiveness of a preservation are determined by the following factors:

- Implemented preservation measures
- Implemented packaging
- Maximum storage period

Only careful implementation and tuning of these measures ensures a sufficient protection of the engine and the accessories. For storage of individual packing pieces please additionally refer to ***operating instructions, chapter "Transportation and Packaging", paragraph "Storage of Packing Pieces"***.

The different climatic conditions of the respective storage location and/or destination as well as the intended period of storage determine the kind and scope of the measures for **light** or **heavy-duty preservation**.

	⚠ WARNING
<p>Risk of injury.</p> <p>For preservation some components must be disassembled and afterwards reassembled. This involves a considerable risk of injury.</p> <p>> The disassembly and reassembly work is to be carried out and/or supervised by professionals specifically trained on the engine.</p>	

5.2.1 Light Preservation

Light preservation (see ***operating instructions, chapter "Storage and Preservation", paragraph "Light Preservation"***) is carried out for a shut down of the engine with following storage of up to 2 months in Central European areas. It is also suitable for carriage by road within Central Europe.

5.2.2 Heavy-Duty Preservation

Heavy-duty preservation (see ***operating instructions, chapter "Storage and Preservation", paragraph "Heavy-Duty Preservation"***) is to carried out if the engine is shut down for more than 2 months, but not longer than 1 year and stored in Central European areas. These measures also apply for transport on board (under deck) of seagoing ships into international areas.

	NOTE
	<p>The preservation measures particularly for subtropical or tropical areas are to be coordinated with Caterpillar Motoren GmbH & Co. KG depending on the destination and storage location and the intended storage period.</p>

5.2.3 Packaging/Storage

The measures for storage and packaging depend on storage period and location.

Light preservation (see *operating instructions, chapter "Storage and Preservation", paragraph "Light Preservation"*) provides sufficient protection when stored and placed in well ventilated machine rooms/halls and when transported on road under Central European climatic conditions.

For storage in the open the engine is to be carefully protected against atmospheric influences with a water resistant tarpaulin or tear-resistant plastic film. Protect tarpaulin/film against mechanical damage.

Sufficient ventilation below the covering must be ensured. In Central Europe check tarpaulin and preservation regularly every 4 weeks.

In case of worse climatic conditions than in Central Europe, the measures of a heavy-duty preservation (see *operating instructions, chapter "Storage and Preservation", paragraph "Heavy-Duty Preservation"*) are to be carried out and the engine as well as the accessories below the tarpaulin are to be checked every 2 weeks.

Immediately remedy any damage that is identified. Remove already existing corrosion and renew the preservation.

In case of risk of frost immediately ensure adequate freeze protection, see *engine documentation, chapter "Operating Media", paragraph "Lubricating Oil"* and *"Cooling Water"* respectively and *operating instructions, chapter "Storage and Preservation", paragraph "Heavy-Duty Preservation"*.

5.2.4 Depreservation

The measures for depreservation (see *operating instructions, chapter "Storage and Preservation", paragraph "Depreservation"*) are to be carried out and observed according to the implemented measures for a short term or long term preservation **prior** to commissioning of the engine.

5.3 Light Preservation (Short-Term Preservation)

Required tools, preservation, cleaning, and auxiliary materials:

- Spraying gun, injection pipe, brush, rag
- Sprayable, non drying preservation oil (e.g. Aral Konit SAE 30)
- Corrosion preventative, viscous, adhesive, drying (e.g. Valvoline Tectyl 506)
- Anticorrosion oil (e.g. Rust Ban 310)
- Anti-freeze agent (e.g. Glysantin)
- Solvent-free washing or cleaning agent

	<p style="text-align: center;">CAUTION</p> <p>The engine's coat of paint must not be etched by the cleaning or washing agent.</p> <p>Its coat of paint may be affected when preserving the engine.</p> <ul style="list-style-type: none"> > Only use washing agents that are suitable for the purpose. > Follow the instructions of the manufacturer regarding application, safety and disposal.
---	--

5.3.1 Engine Preservation Measures

The preservation measures for the individual engine parts must be carried out according to the following sequence of operations.

5.3.1.1 Fuel System

- If the engine is running on heavy fuel, change over to distillate fuel, see *engine documentation, chapter "Operational Monitoring", paragraph "Changing the Type of Fuel"*.
- Clean the fuel duplex filter, see *engine documentation, chapter „Maintenance“, job card A5.05.07.12.01.nn*.
- Prepare a mixture of distillate fuel and anticorrosion oil at a ratio of **1 : 1**. This requires a separate vessel with a corresponding shut-off valve to be incorporated into the distillate fuel system. The required amount of fuel **B (litres)** for **15 - 20 min.** running time depends on the engine type and can be determined approximately with the following formula:

$$B \text{ (ltr)} = 7 \times \frac{\text{Rated power (kW)}}{1000}$$

- Operate the warmed up engine with the fuel/anticorrosion mixture at **75%** of the nominal speed and low load.

	NOTE
	<p>If the engine is separated from the plant, run the engine until the fuel system is empty. Then firmly seal each connection point with a blank flange or a sheet metal cover.</p>

5.3.1.2 Lubricating Oil System

- Clean the duplex filter, see *engine documentation, chapter „Maintenance“, job card A5.05.08.04.01.nn.*

	NOTE
	<p>The lubricating oil remains in the circuit if the values required for engine operation (see <i>engine documentation, chapter "Operating Media", paragraph "Lubricating Oil"</i>) are kept.</p> <p>> Recommendation: Pump fresh lubricating oil through the lubricating oil circuit of the engine until clean oil leaks out at the last camshaft bearing.</p>

- Only drain the lubricating oil if the engine is separated from the plant. Firmly seal each connection point with a blank flange or a sheet metal cover.

5.3.1.3 Cooling Water System

- Cool the engine down to **30 °C** and drain the cooling water.

	NOTE
	<p>The cooling water chambers are protected by the corrosion preventatives in the cooling water (see <i>engine documentation, chapter "Operating Media", paragraph "Cooling Water"</i>).</p>

5.3.1.4 Crankcase, Main Running Gear, Camshaft, Lower Valve Drive, Fuel Pump Drive, Charge Air Duct

- Spray the components with preservation oil. Take particular care to make sure that all areas of crankshaft, camshaft, connecting rods, and gear wheels are reached.
- Open charge air duct, spray with preservation oil from the inside and close again.

5.3.1.5 Upper Valve Drive

- Loosen and remove the valve cover.
- Clean the contact face of the valve cover.
- Spray the superstructural parts of the cylinder head with preservation oil.

- Put on and bolt down the valve cover.

5.3.1.6 Outside Preservation

- Clean or wash if necessary all bare metal, unpainted parts of the engine.

	<h3>CAUTION</h3>
	<p>The engine's coat of paint must not be etched by the cleaning or washing agent.</p> <p>Its coat of paint may be affected when preserving the engine.</p> <ul style="list-style-type: none"> > Only use washing agents that are suitable for the purpose. > Follow the instructions of the manufacturer regarding application, safety and disposal.

- Leave the cleaned parts to dry and then coat with drying corrosion preventative.

5.3.1.7 Preservation Measures for Accessories and Tools

For preservation instructions please refer to *operating instructions, chapter "Storage and Preservation", paragraph "Heavy-Duty Preservation"*).

5.4 Heavy-Duty Preservation (Long-Term Preservation)

Required tools, preservation, cleaning, and auxiliary materials:

- Spraying gun, injection pipe, brush, rag
- Sprayable, non drying preservation oil (e.g. Aral Konit SAE 30)
- Corrosion preventative, viscous, adhesive, drying (e.g. Valvoline Tectyl 506)
- Non drying anticorrosion grease (e.g. Shell ALVANIA 3)
- Governor oil (e.g. Hydrol DO 46)
- Fresh turbine or hydraulic oil (see *engine documentation, chapter "Operating Media", paragraph "Lubricating Oil"*)
- Solvent-free washing or cleaning agent
- Plastic protective plug (e.g. Kapsto shipping plug GPN)

	<h3>CAUTION</h3>
	<p>The engine's coat of paint must not be etched by the cleaning or washing agent.</p> <p>Its coat of paint may be affected when preserving the engine.</p> <ul style="list-style-type: none"> > Only use washing agents that are suitable for the purpose. > Follow the instructions of the manufacturer regarding application, safety and disposal.

5.4.1 Engine Preservation Measures

In case of a shut down of the engine for longer than 2 months, the following work is to be carried out in addition to the measures stated in the *engine documentation in chapter "Storage and Preservation", under paragraph "Light Preservation"*:

5.4.1.1 Combustion Chamber and Cylinder Liner

- Open the indicator valves.
- Turn the first cylinder in direction of rotation of the engine to BDC, exhaust valve open.
- Blow preservation oil with spray gun and injection pipe through the indicator bore into the combustion chamber.
- Continue to turn the engine in direction of rotation until TDC is reached and the inlet valves are open and spray the inlet valves also with preservation oil.
- Repeat this procedure on each cylinder.
- Close the indicator valves.

5.4.1.2 Starting System, Starting Air Filter

- Remove the blank flange from the starting air distributor.
- Remove the drain plug on the starting valve as well as the banjo plugs of the control air pipes on the starting valves of all cylinders.
- Spray preservation oil through the distributor. While spraying, open the starting valves several times by means of a drift inserted through the control air bores.
- Preservation oil must leak out of the control apertures.
- Remount banjo plugs, drain plug, and flange.
- Remove banjo plug of the starting air system. Spray in preservation oil and close the banjo plug again .

5.4.1.3 Speed Governor (Mechanical-Hydraulic)

- Fill governor according to manufacturer documentation (see *engine documentation, chapter "External Documentation"*) up to the rim with governor oil.
- Apply non-drying preservation grease to the gear wheels behind the governor dial.

5.4.1.4 Turbocharger

	NOTE
	<p>If the engine is separated from the plant:</p> <ul style="list-style-type: none"> – Blank off the exhaust gas flange with cap and gasket – Wrap the air filter with polyethylene foil and glue so as to be air tight – Protect the foil against damage due to shocks (if necessary by means of a slatted frame).

- Observe the manufacturer documentation (see *engine documentation, chapter "External Documentation"*). If necessary, carry out further preservation measures according to instructions of manufacturer.

5.4.1.5 Outside Preservation

- Close the crankcase ventilation with protective plugs so that it is air tight.
- Clean or wash if necessary all bare metal, unpainted parts of the engine.

	CAUTION
	<p>The engine's coat of paint must not be etched by the cleaning or washing agent.</p> <p>Its coat of paint may be affected when preserving the engine.</p> <ul style="list-style-type: none"> > Only use washing agents that are suitable for the purpose. > Follow the instructions of the manufacturer regarding application, safety and disposal.

- Coat the cleaned parts with drying corrosion preventative.
- After drying apply a second coat of corrosion preventative in order to ensure sufficient coat thickness.

5.4.2 Preservation Measures for Accessories and Tools

- Thoroughly clean the small parts.
- If necessary, cover threads, bores, grooves and similar with self-adhesive aluminium foil.
- Then seal the small parts in an immersion bath with thermoplastic.
Do not use the immersion bath procedure for bigger and more complex parts. Coat the bare metal parts of these with drying corrosion preventative and pack them in oil paper.
- Package loose parts and tools in a wooden box lined with bituminized felt. Make sure all parts are secured in the box.
- Cover the opening of the box with plastic foil prior to putting on the top cover.

	CAUTION
	<p>Loose parts and tools may be subject to corrosive attack during storage.</p> <p>The aforesaid packaging is sufficient for sea transportation (below deck) and storage of up to 6 months.</p> <ul style="list-style-type: none"> > In case of longer storage time (up to a maximum of 1 year) all non immersed loose parts must be shrink-packed.

5.5 Depreservation

Required Cleaning Agents and Auxiliary Materials

- Fresh turbine or hydraulic oil (see *engine documentation, chapter "Operating Media", paragraph "Lubricating Oil"*)
- Solvent-free washing or cleaning agent

	<h3>CAUTION</h3>
	<p>The engine's coat of paint must not be etched by the cleaning or washing agent.</p> <p>Its coat of paint may be affected when preserving the engine.</p> <ul style="list-style-type: none"> > Only use washing agents that are suitable for the purpose. > Follow the instructions of the manufacturer regarding application, safety and disposal.

5.5.1 Depreservation Measures

The following measures are to be implemented after a light or heavy-duty preservation.

5.5.1.1 General Work

- Depending on the measures that were taken in connection with preservation restore the engine to working condition. This includes removing any protective plugs, covers, blank flanges or other seals/foils and any locking devices.
- Reconnect the engine to the overall system if a separation was carried out.

5.5.1.2 Fuel System

- No depreservation, even if the piping system is still filled with the mixture used for the light preservation run.
- Restart the engine with the mixture that may have remained in the system.

5.5.1.3 Lubricating Oil System

- No depreservation measures.
- If the lubricating oil was drained, refill with the required grade (see *engine documentation, chapter "Operating Media", paragraph "Lubricating Oil"*).

5.5.1.4 Cooling Water System

- Check the condition of the cooling water spaces and flush with freshwater if necessary.
- If instead of an anti-corrosion emulsion chemical corrosion preventatives are to be used, flush the entire system with an alkaline cleaning solution (see **engine documentation, chapter "Operating Media", paragraph "Cooling Water"**).

5.5.1.5 Speed Governor (Mechanical-Hydraulic)

- Lower the oil level in the governor to the specified level.
- Governor dial:
Remove any excess preserving grease from the pinions behind the governor dial.

5.5.1.6 Turbocharger

- If necessary, clean the preserved parts according to instructions of the manufacturer.

5.5.1.7 Outside Depreservation

- Remove corrosion preventative completely from all coated, bare metal engine parts, if necessary, remove by washing.

	<h2>CAUTION</h2>
	<p>The engine's coat of paint must not be etched by the cleaning or washing agent.</p> <p>Its coat of paint may be affected when preserving the engine.</p> <ul style="list-style-type: none"> > Only use washing agents that are suitable for the purpose. > Follow the instructions of the manufacturer regarding application, safety and disposal.

6 Commissioning

6.1 Safety Notes

Danger in case of non-observance of warning notices (*please refer to **chapter Safety***).

	⚠ DANGER
	<p>Risk of explosion.</p> <p>In the engine block oil mist is forming. At high temperatures in combination with oxygen from the ambient air this may lead to explosion.</p> <ul style="list-style-type: none"> > Arrange warning notices on the protective covers closing the inspection openings in the engine block. > Before opening the protective covers in front of the inspection openings wait 20 minutes until the engine has cooled down.

	⚠ DANGER
	<p>Danger of death due to electricity.</p> <p>There is danger of death when coming in contact with live wires or components.</p> <ul style="list-style-type: none"> > Before carrying out any work switch off the power supply and secure it against being switched on again.

	⚠ WARNING
	<p>Failure of the emergency stop and oil mist detector safety devices.</p> <p>Besides the starting system the air system of the engine also supplies air to the emergency stop device and the oil mist detector. If the shut-off valve is closed, the emergency stop and oil mist detector safety devices will fail.</p> <ul style="list-style-type: none"> > Do not close the shut-off valve for starting air during operation.



⚠ WARNING

Danger of death due to suspended load.

When lifting a load there is danger of death due to parts that may fall down or swing in an uncontrolled manner.

- > Never stand under a suspended load.
- > Observe the specifications regarding the provided lifting points.
- > Do not sling to projecting machinery parts or eyes of fitted components. Ensure perfect fit of the slings.
- > Only use approved hoists and slings of sufficient capacity.
- > Do not use ropes and belts that are cracked superficially or abraded.
- > Do not attach ropes and belts to sharp edges and corners, do not knot and twist.



⚠ CAUTION

Risk of burns.

All components of the engine will become hot during operation. There is a risk of burns.

- > Only touch components after the engine has cooled down.
- > Arrange warning notices on the engine.







⚠ CAUTION

Risk of slipping.

Oil may leak out of the engine. There is a risk of slipping.

- > Clean the engine regularly.
- > When carrying out work on the cylinder heads wear fall protection.
- > Arrange warning notices on the engine.

Wear the following protective equipment for all installation and initial commissioning work:

	Close fitting protective clothes with low tensile strength
	Safety shoes with steel toes and oil-resistant safety sole
	Protective gloves as protection against injuries
	Ear protection in environments where noise emission exceeds 85 dB(A)
	Safety glasses to protect the eyes from flying debris and splashing liquids

	NOTE
	Further protective equipment required for certain work will be indicated specifically in the warning notices of this chapter.

6.2 Personnel Qualification

	NOTE
	<p>Work on the electrical installation may only be carried out by specialist electricians.</p>

The operating personnel must have the corresponding qualification and authorization (certificate of competence) for operating an engine plant.

Before commissioning a specific plant the operating personnel must familiarize themselves with the particular characteristics of the plant.

Training regarding the plant specific requirements/characteristics may, if required, be provided by order of the operator of the plant in the Training Center of Caterpillar.

Initial commissioning will be carried out by one of our qualified technicians who will explain the plant in detail to the operating personnel. Clarify any detail questions on site based on the operating instructions and note down any explanations in these instructions. After commissioning capture all data and work that is important for the engine in an operational monitoring log or in a computer aided maintenance management system (CMMS).

6.3 Running-in Instructions

All engines leaving our works have been fully run in, thus no further running in instructions are required.

In case of certain repairs such as overhaul work on **pistons (A5.05.02.10.01.nn)**, **piston rings (A5.05.02.07.01.nn)**, and **cylinder liners (A5.05.03.04.02.nn)** (see *engine documentation, chapter „Maintenance“, job cards*) the following instructions must be observed as will be pointed out on the respective job cards as well:

- After preheating the engine start at 20 % rated power and then increase up to full power within 8 hours.

Heavy fuel engines that are to be run in again within **20 %** and **50 %** of their rated power are to be run with distillate fuel during part load operation due to the increased amount of combustion residues generated (see *operating instructions, chapter "Operational Disturbances" paragraph "Part Load Operation of Heavy Fuel Plants"*)

While increasing the power output compare the pressures and temperatures with the values of the **acceptance test record**, see *engine documentation, chapter "Technical Engine Data"*, in order to assess the operating condition of the engine.

No running-in instructions are to be observed when a repair has been carried out on the main and big-end bearings.

6.4 Fuel System

After a longer shutdown, prior to commissioning for heavy fuel and distillate fuel operation:

- Remove the fuel injectors see ***engine documentation, chapter „Maintenance“, job card A5.05.07.07.01.nn.***
- Check the nozzles and their opening pressure see ***engine documentation, chapter „Maintenance“, job card A5.05.07.08.01.nn.***
- Drain the fuel day tank, remove sludge and refill it.
- Clean the fuel filter see ***engine documentation, chapter „Maintenance“, job card A5.05.07.12.01.nn.***
- Check all shut-off devices for correct switching position.
- Refill and vent the fuel system.

Use the standby feed pump. If the fuel day tank is located on a higher level and there is a bypass line open the shut-off valve on the pump.

- Check the control rod with related linkage for ease of movement.
Check each individual control rod for proper function by pulling/pressing it into both directions.
- Set all valves and fittings in the fuel system to operating position.
- Switch on the fuel circulating pump and check the vent screws, flange connections, and pipe unions for leaks.

Additional preparations for heavy fuel operation

(see ***operating instructions, chapter "Regulations for Heavy Fuel Operation", paragraph "Fuel System"***)

- Switch on the preheating of all units required for operation in a timely manner.
- Switch on the fuel circulating pump.

Check the fuel temperature before injection pumps according to its viscosity (see ***engine documentation, chapter "Technical Engine Data"***).

6.5 Lubricating Oil System

After longer shutdowns and during operation carry out regular analyses of the circulating lubricating oil (see *engine documentation, chapter "Operating Media"*).

- Clean the lubricating oil duplex filter and the suction strainers before lubricating oil pressure pump and lubricating oil standby-pump (see *engine documentation, chapter „Maintenance“, job cards A5.05.08.02.01.nn, A5.05.08.04.01.nn*).
- Dry sump
 - Drain the lubricating oil circulation tank.
 - Check the oil level.
- Wet sump
 - Check the oil level in the oil pan by means of a dipstick.
- Switch on the lubricating oil standby or prelubrication pump and
 - Vent the entire lubricating oil system.
 - Check all flange and threaded connections in the lubricating oil system for leaks.
 - Check the lubricating oil supply of the following lubrication points:
 - Big-end and small-end bearings
 - Main bearings
 - Camshaft bearings
 - Rocker arms
 - Oil nozzles for timing gear train
 - Oil nozzles for pump drives
- A slight oil flow must be visible.
 - Check the lubricating oil pressure. The operating pressure (see *engine documentation, chapter "Technical Engine Data"*) must be reached when the standby or prelubrication pump is switched on.

Plants with lubricating oil separator:

- Start separating the lubricating oil in a timely manner before commissioning of the engine and preheat the lubricating oil this way.

6.6 Cooling Water System

- Fill the cooling water system via the expansion tank. For cooling water requirements and water treatment with corrosion preventatives please see *engine documentation, chapter "Operating Media"*.
- Check shutoff and changeover devices for correct position based on the cooling water schema, see *engine documentation, chapter "External Documentation"*.
- Switch on the freshwater standby pump and check the cooling system for leaks.
- If there are shut-off devices in the cooling water piping of the engine for draining individual cooling water spaces in case of a repair (e.g. cylinder head, turbocharger, etc.), check whether all shut-off devices are open, so that there will be no heat accumulation on the heat removing parts.
- Unless connected to a permanent venting arrangement, all components and pipes belonging to the system must be vented one after the other. The vent pipe from the engine to the expansion tank generally has a shut-off valve to throttle the water flow. During operation sufficient permanent venting must be ensured.
- Preheat the engine in good time before starting: Switch on the preheater and circulating pumps or, if the cooling water circuits are connected to other engines already running, open the corresponding shut-off valves.
If an engine is running on heavy fuel from pier to pier, preheating is absolutely necessary. In case of operation on distillate fuel the starting performance is better, water condensation is avoided, and the time needed until the engine reaches normal operating temperature is considerably shorter.
- For preheating temperature please see *operating instructions, chapter "Putting into Service"*.
- For pressure and temperature values please see *engine documentation, chapter "Technical Engine Data"*.

6.7 Starting Air System

For operational safety of the engine it is absolutely required that the starting air supply is always open during operation of the engine.



⚠ WARNING

Failure of the emergency stop and oil mist detector safety devices.

Besides the starting system the air system of the engine also supplies air to the emergency stop device and the oil mist detector. If the shut-off valve is closed, the emergency stop and oil mist detector safety devices will fail.

- > Do not close the shut-off valve for starting air during operation.

6.8 General Functional Check

- Ensure sufficient engine room ventilation.
- Drain the exhaust duct after turbocharger and check for free passage.
- Check the permanent drain of the charge air duct for free passage.
On a cold engine a small quantity of water may leak out due to condensate formation.

	<p>NOTE</p> <p>If a bigger quantity of water leaks out, identify the cause. In such a case do not start the engine due the risk of hydraulic lock.</p>
---	---

- Open the decompression/indicator valve.
- Turn the engine by means of a barring gear or barring rod. For **plants with a clutch**
 - declutch the engine
- Continue to carry out starting attempts until no more water is blown out.
- Close the decompression/indicator valve. The engine is ready for commissioning.

6.9 Commissioning

6.9.1 Putting into Service / Starting

Depending on the intended use of the engine and the degree of automation there are, in addition to the basic equipment for direct control on the engine (emergency control), further special control devices for the functions to be carried out. These will not be treated in this chapter.

If these devices are included in the Caterpillar scope of supply, a functional schema and a description were prepared which are specifically matched to this plant, see "**engine documentation, chapter "External Documentation"**".

Direct start on the main engine

Within the scope of this commissioning only the direct starting procedure on a main engine will be treated.

It is required to know the degree of automation of the plant in order to ensure functionality of the complete plant.

If alarm and safety devices as well as the rpm switch unit are switched off, all functions that are normally captured automatically must be checked or performed manually.

Normal start (control panel in the gauge board)

- Set change-over switch **S13** to "**1 = Engine**".
- Set emergency stop lever (**10**) on the control stand/control linkage to operating position.
- Prelubricate the engine.
- Switch on the prelubrication / lubricating oil standby pump about 5 minutes before starting the engine. Operating pressure see **engine documentation, chapter "Technical Engine Data"**.
- Adjust the speed on speed setting knob **R1** slightly higher than n_{min} .

	<h3 style="margin: 0;">NOTE</h3>
<p>In case of a failure of the electronic-electrical governor it is possible to carry out the speed regulation on the speed setting knob of the mechanical-hydraulic governor.</p> <ul style="list-style-type: none"> • Press button S11 "Start". • Switch off the prelubrication / standby pump (automated, otherwise by hand). <p>Slowly run up the engine to operating temperature according to its temperature level, see operating instructions, chapter "Commissioning", paragraph "Putting into Service".</p>	

6.9.2 Loading during Warming up of a Main Engine

Prerequisite: The jacket water has been preheated to temperature (t) when running on:

Distillate fuel	t =40 °C
Heavy fuel	t >=10 °C below operating temperature at engine outlet or engine inlet, see <i>engine documentation, chapter "Technical Engine Data"</i> .

Normal loading

Unless loading is controlled by a programme, the load can be increased to **60 %** within **1 minute** and to full load within further **3 - 4 minutes**.

Cold starting, start below the preheating temperature indicated above

Caterpillar generally advises against cold starting because of higher wear and high thermal load on the parts forming the combustion chamber.

Only the following brief instructions are therefore given:

It is possible to **start a cold engine** on distillate fuel, however, this should only be done in **exceptional cases**. Very careful warming up will then be absolutely required.

The conditions for **starting a cold engine** on heavy fuel are very restricted. In addition to the above thermal influences, however, increasingly difficult ignition will have to be expected with rising fuel viscosity. As a consequence of incomplete combustion, the combustion chambers and exhaust system will be covered by heavy deposits subjecting pistons and liners to severe wear.

	NOTE
	Carry out cold starting on heavy fuel only in an extreme emergency case.



Operating Instructions Commissioning

M20/M25/M32/M43

The engine should always reach working temperature after every start, particularly in case of short test runs. Running the engine for a short time will produce sulphurous acid, which, in combination with other aggressive combustion residues, will cause corrosion on the valves and in the exhaust ducts.

With local control or manual monitoring of the engine, the indicators such as pressure gauges, thermometers, and tachometers must be continuously watched. The local control stand may only be left when the operating values have reached a steady state condition in the required power range.

If there is a barred speed range due to torsional vibration, this should be passed as quickly as possible. See the information plate (see *engine documentation, chapter "Structure and Function", paragraph "Nameplate"*) on the engine or *engine documentation, chapter "Technical Engine Data"*.

7 Regulations for Distillate Fuel Operation

7.1 Fuel System

For information about heavy fuel quality as well as regulations and maintenance see **engine documentation, chapter "Operating Media", paragraph "Fuel"**.

7.1.1 Maintenance and Monitoring

The less data there is on the quality of the bunkered distillate fuel, the more carefully it must be treated and monitored.

Fuel	Injection viscosity	Temperature after final pre-heater	Required system pressure
mm ² /s at 40°C	mm ² /s	°C	bar
6	12	no preheating	5,0
11	12	50	5,0
14	12	50	5,0

The indicated pressures are minimum values. The pressures at engine inlet indicated in the technical data are to be kept.

M20/M25/M32/M43

Single-engine plant.

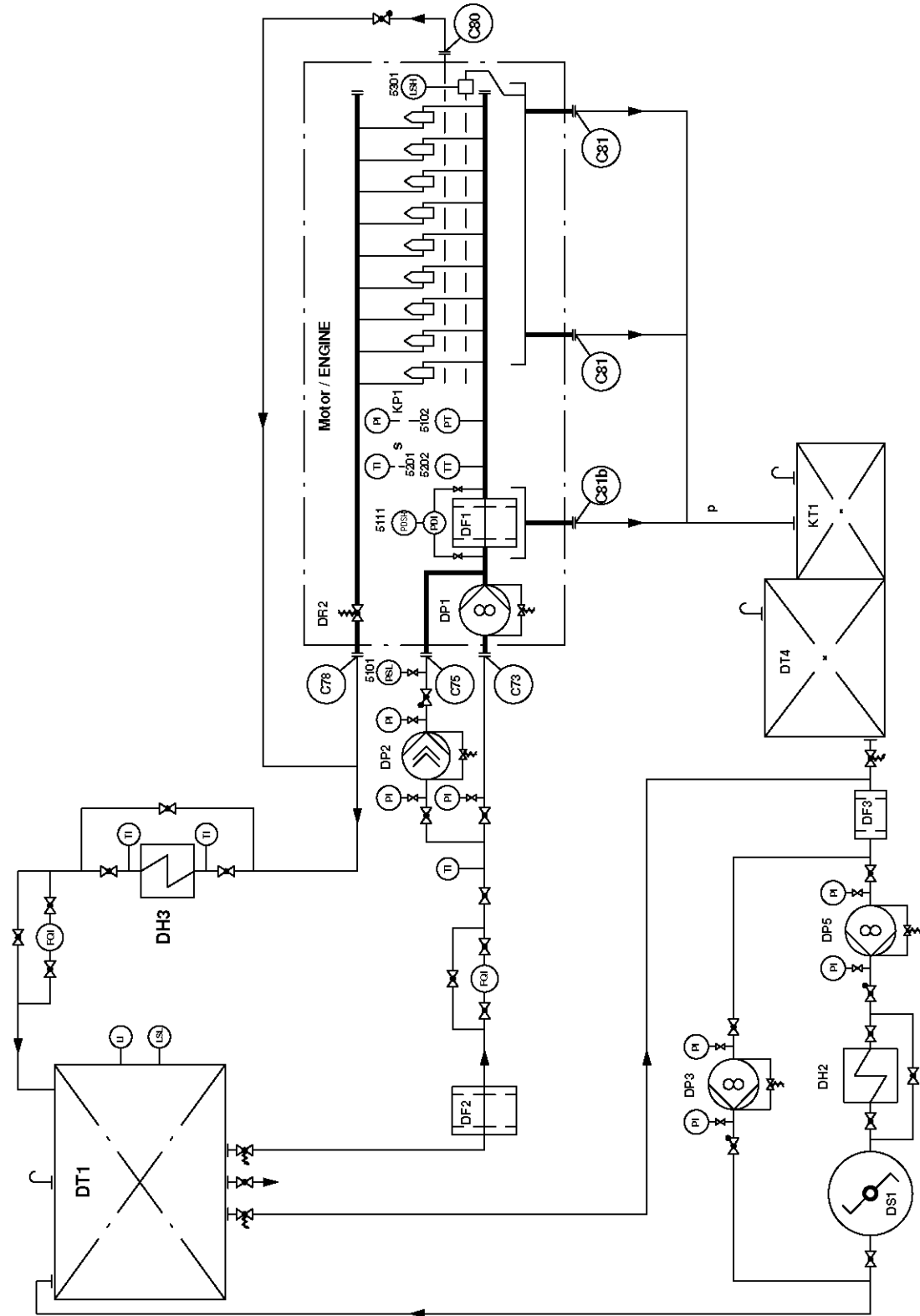

Aggregate und Armaturen/ACCESSORIES AND FITTINGS

DF1	Kraftstoff-Feinfilter (Doppelfilter) / FUEL FINE FILTER (DUPLEX FILTER)
DF2	Kraftstoff-Vorfilter (Doppelfilter) / FUEL PRILIMINARY FILTER (DUPLEX FILTER)
DF3	Kraftstoff-Grobfilter / FUEL COARSE FILTER
DH2	Dieseloel-Vorwaermer (Separator) / ELECTRICAL PREHEATER FOR DIESEL OIL (SEPARATOR)
DH3	Dieseloelkuehler / GASOIL COOLER
DP1	Dieseloel-Zubringerpumpe / DIESEL OIL FEED PUMP
DP2	Dieseloel-Reserve-Zubringerpumpe / DIESEL OIL STAND-BY FEED PUMP
DP3	Dieseloel-Foerderpumpe (zum Tagestank) / DIESEL OIL TRANSFER PUMP (TO DAY TANK)
DP5	Dieseloel-Foerderpumpe (Separator) / DIESEL OIL TRANSFER PUMP (SEPARATOR)
DS1	Dieseloel-Separator / DIESEL OIL SEPARATOR
DT1	Dieseloel-Tagestank / DIESEL OIL DAY TANK
DT4	Dieseloel-Vorratstank / DIESEL OIL STORAGE TANK
KP1	Kraftstoff-Einspritzpumpe / FUEL INJECTION PUMP
KT1	Leckkraftstofftank / DRIP FUEL TANK
FQI	Kraftstoffmessuhr / FLOW QUANTITY INDICATOR
LI	Niveauanzeige / LEVEL INDICATOR
LSH	Niveauwaechter (Niveau zu hoch) / LEVEL SWITCH HIGH
LSL	Niveauwaechter (Niveau zu niedrig) / LEVEL SWITCH LOW
PDI	Differenzdruckanzeige / DIFF. PRESSURE INDICATOR
PDSH	Differenzdruckwaechter (Druck zu hoch) / DIFF. PRESSURE SWITCH HIGH
PI	Manometer / PRESSURE INDICATOR
PSL	Druckwaechter (Druck zu niedrig) / PRESSURE SWITCH LOW
PT	Druckumformer/PRESSURE TRANSMITTER
TI	Thermometer / TEMPERATURE INDICATOR
TT	Temperaturfuehler (PT100)/TEMPERATURE TRANSMITTER (PT100)

Trennstellen / DISCONNECTING POINTS:

C 73	Eintritt angeb. Kraftstoffpumpe / FUEL INLET, TO ENGINE FITTED PUMP
C 75	Anschluss, Reservepumpe / CONNECTION, STAND-BY PUMP
C 78	Austritt Sammelleitung / FUEL OUTLET
C 80	Leckkraftstoffanschluss / DRIP-FUEL CONNECTION
C 81	Leckkraftstoffanschluss / DRIP-FUEL CONNECTION
C 81b	Leckkraftstoffanschluss / DRIP-FUEL CONNECTION

M20/M25/M32/M43

Multi-engine plant

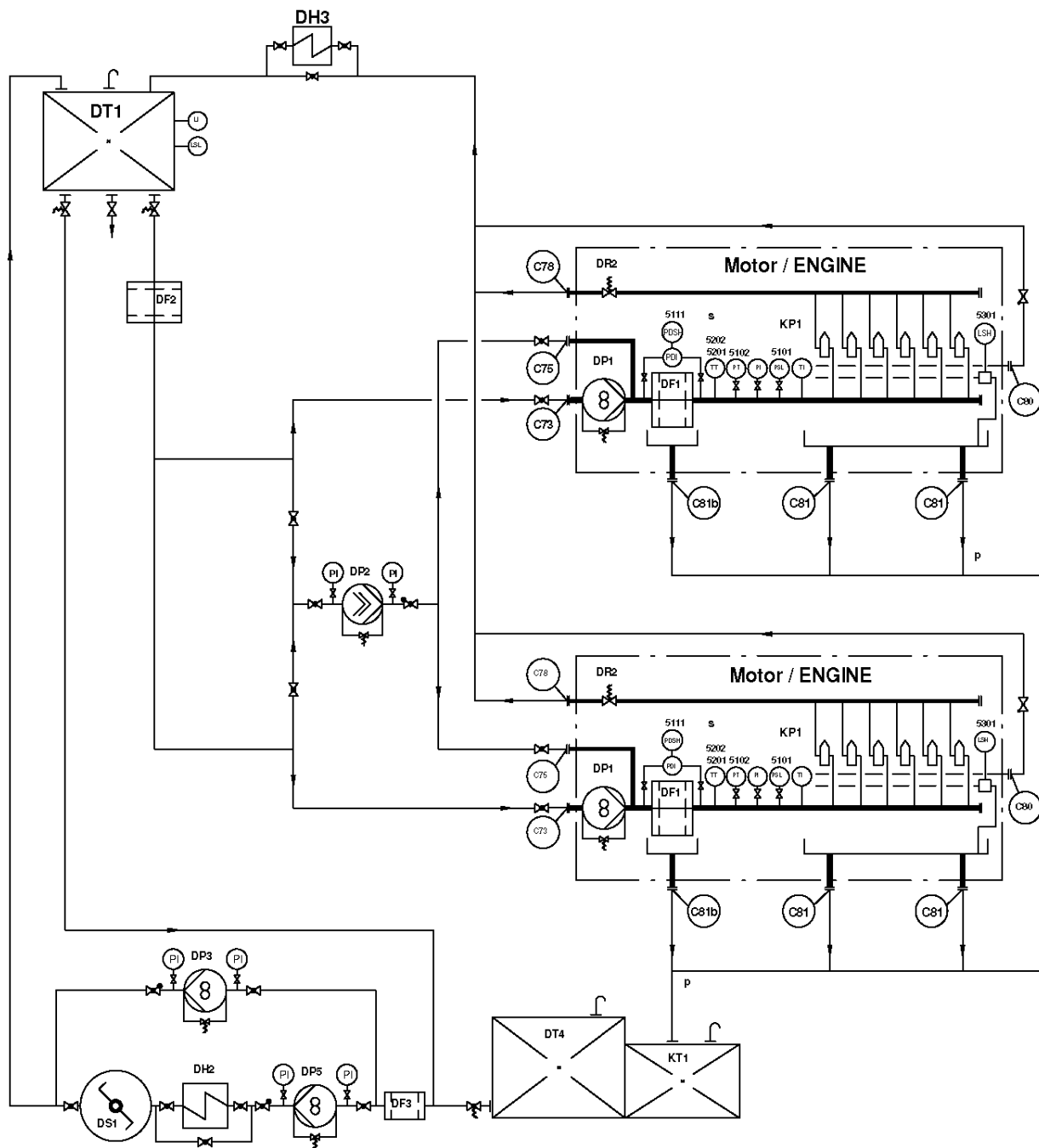

Aggregate und Armaturen/ACCESSORIES AND FITTINGS

DF1	Kraftstoff-Feinfilter (Doppelfilter) / FUEL FINE FILTER (DUPLEX FILTER)
DF2	Kraftstoff-Vorfilter (Doppelfilter) / FUEL PRIMARY FILTER (DUPLEX FILTER)
DF3	Kraftstoff-Grobfilter / FUEL COARSE FILTER
DH2	Dieseloel-Vorwaermer (Separator) / ELECTRICAL PREHEATER FOR DIESEL OIL (SEPARATOR)
DH3	Gasoeel-Kuehler/GASOIL COOLER
DP1	Dieseloel-Zubringerpumpe / DIESEL OIL FEED PUMP
DP2	Dieseloel-Reserve-Zubringerpumpe / DIESEL OIL STAND-BY FEED PUMP
DP3	Dieseloel-Foerderepumpe (zum Tagestank) / DIESEL OIL TRANSFER PUMP (TO DAY TANK)
DP5	Dieseloel-Foerderepumpe (Separator) / DIESEL OIL TRANSFER PUMP (SEPARATOR)
DR2	Kraftstoff-Druckhalteventil / FUEL PRESSURE REGULATING VALVE
DS1	Dieseloel-Separator / DIESEL OIL SEPARATOR
DT1	Dieseloel-Tagestank / DIESEL OIL DAY TANK
DT4	Dieseloel-Vorratstank / DIESEL OIL STORAGE TANK
KP1	Kraftstoff-Einspritzpumpe / FUEL INJECTION PUMP
KT1	Leckkraftstofftank / DRIP FUEL TANK
LI	Niveauanzeige / LEVEL INDICATOR
LSH	Niveauwaechter (zu hoch) / LEVEL SWITCH HIGH
LSL	Niveauwaechter (zu niedrig) / LEVEL SWITCH LOW
PDI	Differenzdruckanzeige / DIFF. PRESSURE INDICATOR
PDSH	Differenzdruckwaechter (zu hoch) / DIFF. PRESSURE SWITCH HIGH
PI	Manometer / PRESSURE INDICATOR
PSL	Druckwaechter (zu niedrig) / PRESSURE SWITCH LOW
PT	Druckumformer / PRESSURE TRANSMITTER
TI	Thermometer / TEMPERATURE INDICATOR
TT	Temperaturfuehler (PT100) / TEMPERATURE TRANSMITTER (PT100)

Trennstellen / DISCONNECTING POINTS:

C 73	Eintritt angeb. Kraftstoffpumpe / FUEL INLET, TO ENGINE FITTED PUMP
C 75	Anschluss Reservepumpe / CONNECTION, STAND-BY PUMP
C 78	Austritt Sammelleitung / FUEL OUTLET
C 80	Leckkraftstoffanschluss / DRIP-FUEL CONNECTION
C 81	Leckkraftstoffanschluss / DRIP-FUEL CONNECTION
C 81b	Leckkraftstoffanschluss / DRIP-FUEL CONNECTION

1. Storage tank

When fueling, only empty storage tanks are to be used. This is to avoid segregation or the consequences of any incompatibility that may occur when taking on different types of fuel.

2. Separator DS1

The separator has the most important task in the fuel treatment. It lowers the content of solids and water to the minimum that can be technically reached.

- The operational capacity is designed according to the rules and regulations of the individual manufacturer, whose authorized department has coordinated the design with **Caterpillar Motoren GmbH & Co. KG**.

Separation temperature **55 °C**.

3. Day tank DT 1

The day tank is designed to collect the treated fuel, for a minimum of hours full load operation. If the treatment plant is in order, it will always be filled to the overflow level. (No formation of water condensation)

- Daily de-sludging is important.
- A temperature level **50 °C** should be maintained.

	CAUTION
<p>There will be an increased component wear rate if desludging does not take place frequently enough.</p> <p>If desludging does not take place daily, this may result in considerable property damage.</p> <p>> Daily desludging is necessary.</p>	

4. Fuel pressure pump DP3, DP5

The fuel pump pressurizes the mixing tank. The pump relief valve has to be closed in operation.

Test procedure:

The system pressure must not rise when increasing the valve spring load.

5. Fuel pressure-regulating valve DR2

This valve is installed in the excess return line and must be set so that the specified pressure is obtained at the engine (see **engine documentation, chapter "Technical Engine Data", paragraph "Working pressures of auxiliary equipment"**).

6. Mixing tank HT2

This tank has a level monitor. In the event of alarm and/or when filling the tank, open the vent valve for a short time by hand.

7. Circulating pump HP3, HP4

This pump has been designed like a force pump. Check that the relief valve is closed as described in (6).

8. Final preheater DH1

The preheater is to lower the fuel viscosity to a level that is optimal for injection, **10 -12 mm²/s cSt; (1,8 - 2 °E)**, in order to reach a good atomization and fuel-air mixture.

- If the preheater is of the electrical type, ensure the temperature switch is set at min. **180 °C**.

If the preheater is of the steam type, a condensation trap should be installed at the steam outlet to ensure sufficient heating is possible.

	NOTE
Fuel temperature at engine inlet <=150 °C	

9. Fine filter HF1

The fine filter protects the fuel injection system and removes solids not previously separated. It is important to clean the filter when **50 %** of the red area on the differential pressure gauge is visible or when the filter alarm has been activated.

For service and maintenance instructions see **engine documentation, chapter "Maintenance"**.

7.2 Lubricating Oil System

The use of distillate fuels of ever declining quality with their inherent contaminants may lead to engine malfunction if lubricating oil maintenance is not adequate.

For this reason, the following instructions point out the importance of a careful lubricating oil maintenance and monitoring of the lubricating oil circuit to ensure trouble-free and economical engine operation.

Lubricating Oil

Suitable lubricating oil has to be selected according to the **engine documentation, chapter "Operating Media", paragraph "Lubricating Oil"**. The limit values specified there have to be observed.

The lubricating oil has a number of important tasks for the operation of the engine such as:

- Replace metallic friction by the much lower fluid friction of the oil film.
- Protect engine parts from corrosive combustion gases.
- Dissipate frictional heat.
- Act as a coolant (piston cooling).
- Support the sealing function between piston, piston rings, and cylinder liner to limit gas blow-by.
- Keep abraded particles, combustion residues, and products of deterioration suspended.

	NOTE
<p>Sulphurous residues and combustion products of the fuel form sulphuric acid with the water vapour which results from combustion and which afterwards condenses. These may cause corrosive wear to bearings, pistons, valves, and cylinder liners.</p>	

7.2.1 Maintenance

If the engine is operated on distillate fuel, it is indispensable to clean the lubricating oil by means of separators because there is no other way to eliminate from the oil the products resulting from the cleaning and neutralisation processes in the refinery such as carbon and asphalt compounds including water.

7.2.2 Lubricating Oil Cleaning

For distillate fuel operation lubricating oil cleaning by separators is recommended.

For limitations of warranty see *operating instructions, chapter "General", paragraph "Warranty"*.

- The separation temperature for MGO/MDO is 85 to 95 °C.
- Maximum admission to the separator 20 % of its capacity rating (see nameplate of separator or pump).

7.2.3 Oil Level Check

- Check the oil level daily, see *operating instructions, chapter "Commissioning", paragraph "Lubricating Oil"*
- Fill up with new oil when 20 % of the circulating quantity are missing. This will add part of the additives that have been consumed.
- An analysis of the circulating lubricating oil is to be carried out on a regular basis during operation and after a longer shutdown, see *engine documentation, chapter "Operating Media", paragraph "Regulations and Maintenance - Lubricating Oil"*

7.2.4 Lubricating Oil System

The lubricating oil pump fitted to the engine draws the oil from the circulation tank via a suction strainer and delivers it to the automatic filter. From there the lubricating oil is delivered to the downstream lubricating oil cooler until it enters the engine via the fitted duplex filter. The lubricating oil is then supplied to the individual lubrication points of the engine so that the pressure at engine inlet remains constant.

GENERAL NOTES
FOR LOCATION, DIMENSIONS AND DES (E.G. FLEXIBLE CONNECTION) OF THE DISCONNECTING POINTS SEE ENGINE INSTALLATION DRAWING.

Allgemeine Hinweise
Lage, Abmessungen und Ausführung (z.B. elastische Verbindung) der Trennstellen siehe Motorenbauezeichnung

Aggregate und Armaturen
ACCESSORIES AND FITTINGS

- LF1 Schmieröl-Doppelfilter/DUPLEX LUBOIL FILTER
- LF2 Schmieröl-Automatikfilter/LUBOIL AUTOMATIC FILTER
- LF4 Schmutzfangter/SUCTION STRAINER
- LH1 Schmierölkühler/LUBOIL COOLER
- LH2 Schmieröl-Anwärmer/LUBOIL PRE-HEATER
- LP1 Schmieröl-Druckpumpe/LUBOIL FORCE PUMP
- LP2 Schmieröl-Reservendruckpumpe/LUBOIL STAND-BY FORCE PUMP
- LP9 Feederpumpe (Separatortank) TRANSFER PUMP (SEPARATOR)
- LR1 Schmieröl-Temperaturregler/LUBOIL THERMOSTAT VALVE
- LR2 Öl-druck-Regulierventil/OIL PRESSURE REGULATING VALVE
- LS1 Schmieröl-Separatortank/LUBOIL SEPARATOR
- LT1 Schmieröl-Umlaufbehälter/LUBOIL SUMP TANK

- LI Niveauanzeige/LEVEL INDICATOR
- LSL Niveauschalter (zu niedrig)/LEVEL SWITCH LOW
- PDI Differenzdruckanzeige/DIFF. PRESSURE INDICATOR
- PSH Differenzdruckwächter (zu hoch)/DIFF. PRESSURE SWITCH HIGH
- PI Manometer/PRESSURE INDICATOR
- PSL Druckwächter (zu niedrig)/PRESSURE SWITCH LOW
- PSLL Druckwächter (zu niedrig)/PRESSURE SWITCH LOW
- PT Drucksensormer/PRESSURE TRANSMITTER
- TI Thermometer/TEMPERATURE INDICATOR
- TSHI Temperaturwächter (zu hoch)/TEMPERATURE SWITCH HIGH
- TT Temperaturfühler (PT1000)/TEMPERATURE TRANSMITTER (PT1000)

Trennstellen/DISCONNECTING POINTS

- C 51 Druckpumpe, Sauganschluss/FORCE PUMP, SUCTION SIDE
- C 53 Schmierölablauf/LUBOIL DISCHARGE
- C 58 Druckpumpe, Drucksseite/FORCE PUMP, DELIVERY SIDE
- C 59 Schmieröleintritt, Doppelfilter/LUBOIL INLET, DUPLEX FILTER
- C 62 Lecköl, Doppelfilter/DRIP OIL, DUPLEX FILTER
- C 91 Kurbelraumventilierung/CRANKCASE VENTILATION TO STACK

Anmerkungen

- h Die Ausführung der Überwachungsgeräte ist der Messrelaisliste zu entnehmen.
- o siehe Vorschriften für die Kurbelraum-entlüftung 4-A-9570.
- p Freier Ablauf erforderlich
- y Kompensator versehen

Pm-M43C-So_mxd01

4 - A - 13118 "

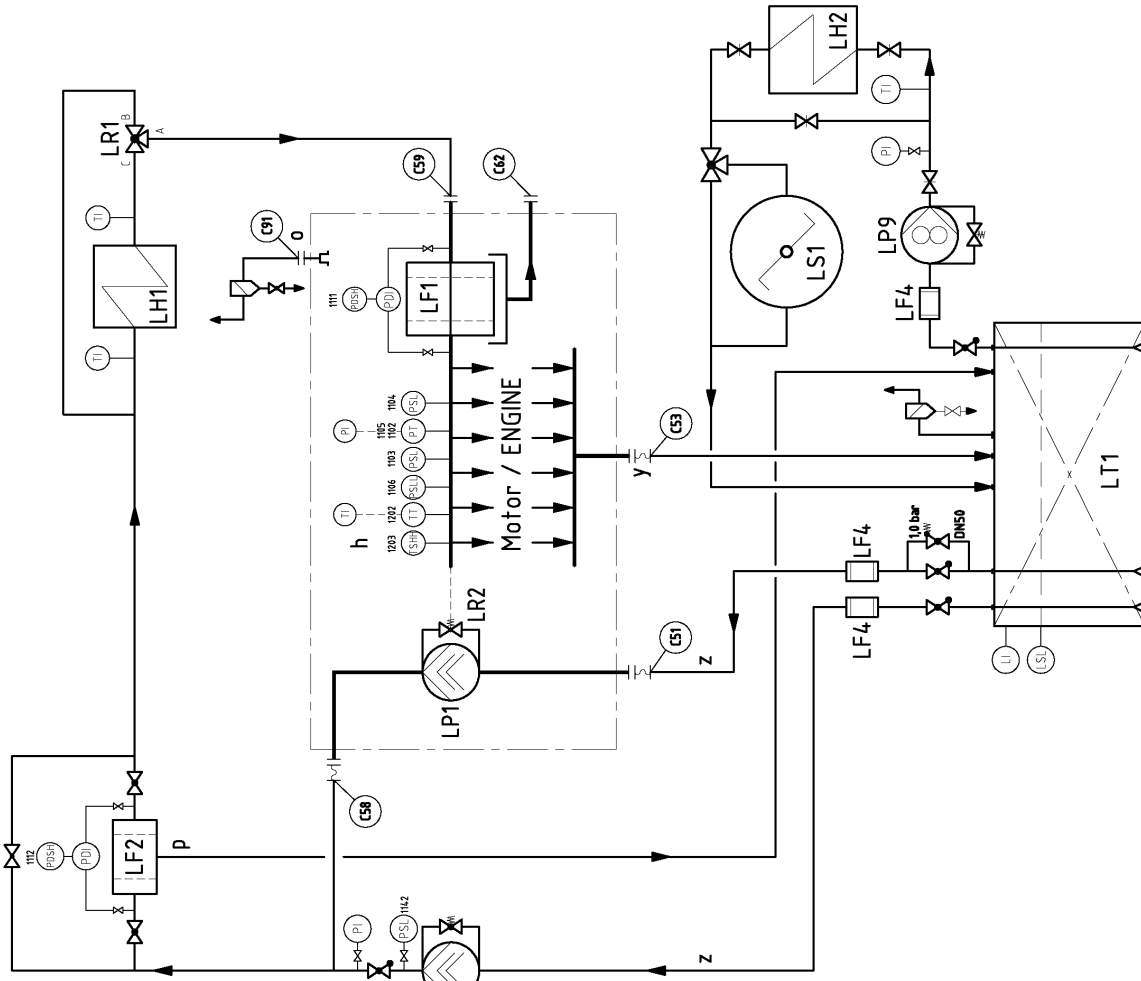

7.2.5 Prelubrication LP2 (Standby/Prelubrication Pump)

Only sufficient prelubrication will produce the necessary oil film on all bearings during the engine starting phase.

- Check the oil pressure build-up at the last main bearing (if there is no automatic engine interlock).
- Continue to prelubricate until the pump pressure has reached a steady state.

7.2.6 Functional Test of the Attached Pressure Pump LP1

Check the oil pressure (at rated speed and operating temperature), if the pressure is too low, carry out the following checks:

- Is the pressure regulating valve LR2 correctly connected (control pipe, relief pipe)?
- Are there no leaks on the overflow valve of the pump?
- Is the suction pipe air tight?
- Are the drain valves closed?
- Is the suction strainer clean?
- Is the flushing quantity of the automatic filter too big?
- Is the pressure regulating valve damaged (spring damaged, orifice plate dirty)?
- Is the pump worn / defective?

7.2.7 Automatic Filter LF2

An automatic backflushing filter with oil and compressed air flushing or an automatic filter with oil flushing is used as automatic filter.

	NOTE
<p>Proper functioning of the entire filter chain is essential for the required filtration of the lubricating oil. Within this chain the automatic filter is the main filter with the finest filtration unit. As a basic rule it is not allowable to bypass this filter.</p>	

Automatic Backflushing Filter LF2 (with Oil and Compressed Air Flushing)

The flushing frequency of the automatic filter depends on the quantity of the dirt particles remaining in the lubricating oil (an indicator of the separator function).

- Monitor the flushing intervals of the filter (flushing cycle counter indicates the degree of contamination).

If there are more than 100 flushing intervals per day, identify the cause of the oil contamination:

- Check the separator for proper function
- Charge air too cold (soot formation)
- Check and clean the filter elements
- If the backflushing filter is flushed with oil, set the flushing flow rate (valve in the backflushing line) so that there will be no drop in operating pressure, (see **engine documentation, chapter "Technical Engine Data"**).
- If a filter alarm occurs on a backflushing filter that is equipped with a flushing oil cleaning insert, clean or replace this insert.

	NOTE
<p>Maintenance instructions see documentation of the manufacturer, engine documentation, chapter "External Documentation".</p>	

Automatic Filter LF2 (with Permanent Oil Flushing)

- Regularly check and clean the filter elements (the differential pressure indicator shows the degree of contamination of the inserts)
- Carefully inspect the elements for damage.
- If on a filter equipped with filter candles only one candle is damaged, this affects the function of the entire filter. Any damaged filter candle must, therefore, be replaced.

	NOTE
<p>Maintenance instructions see documentation of the manufacturer, engine documentation, chapter "External Documentation".</p>	



M32/VM32

7.2.8 Duplex Fine Filter LF1 (Indicator)

Check the filter regularly.

If required (differential pressure indicator shows 50% of the red area or filter alarm), carefully clean the isolated filter chamber with filter candles remaining in place and at operating temperature.

Every third time the filter candles must be removed for cleaning.

Damaged filter candles are to be replaced forthwith.

Maintenance instructions see ***engine documentation, chapter „Maintenance“, job card A5.05.08.04.01.nn.***

7.2.9 Suction Strainer LF4

Clean the suction strainers (customer supply) in the suction pipes of the main, standby, and separating pumps after an interval of 7,500 operating hours each as well as after any work that was carried out on the suction side of the lubricating oil pipe system.

8 Operational Monitoring

8.1 Operation at Low Intake Air Temperatures

If the intake air is preheated or mixed with engine room air so that the temperature before compressor inlet is higher than +10 °C, the engine can be operated at full power output.

Full load at compressor inlet temperatures below +10 °C is only admissible if charge air is blown off after compressor so that the charging pressure does not exceed the values at +20 °C intake air temperature.

At intake air temperatures below +10 °C the engine may only be operated at maximum 90 % rated output because otherwise the approved nominal firing pressure will be exceeded.

8.2 Exhaust System/Firing Pressures

The engine has been designed so that an adjustment/readjustment of commencement of fuel delivery (port closing) or the fuel rack positions of the individual cylinders is no longer necessary. The respective installation heights of the injection pumps of the individual cylinders are secured by ground, cylinder-specific, firmly mounted shims. This measure eliminates all tolerances between the base circle of the cam up to the upper edge of the push rod.

The injection pumps also have very narrow tolerances between the pump foot and the control edge of the pump element so that every pump can be used on every cylinder.

As the camshaft is assembled from individual sections per cylinder, there are minor differences regarding commencement of fuel delivery of the individual cylinders due to the manufacturing tolerances for the angular position of the cams and their accidental summation.

The ignition point is set by means of the camshaft drive gear which has a hydraulically detachable shrink fit for this purpose.

To prevent the existing firing pressure differences from being balanced by adjusting the fuel rack position at the injection pump, the engine does not have such an adjustment possibility. A readjustment of the fuel racks would lead to differing outputs of the individual cylinders.

8.3 Exhaust System - Turbocharging

8.3.1 Exhaust Temperatures, General

The best way to assess the thermodynamic behaviour of the engine is to compare the exhaust gas temperatures with the values from the acceptance test record or the records taken during testing/ sea trials. This will also allow to narrow down any changes (turbocharging, injection, combustion) that may have occurred with regard to new condition. For example, wear on injection pumps or nozzles will directly result in a change in thermal behaviour of the engine. However, the influence of the respective intake conditions on the engine data must be recognized and taken into account.

The **exhaust temperatures after cylinder** cannot be used for an accurate assessment of the power output of the individual cylinders, because the exhaust temperatures from the cylinders captured by means of thermometers are influenced to differing degrees by turbulences in the exhaust manifold. Differences between the individual cylinders in spite of a well balanced power output are quite normal. Such measurements are, therefore, of only limited relevance and may lead to wrong conclusions.

	<p style="text-align: center;">NOTE</p> <p>It is by no means allowable to change fuel rack positions or delivery data to achieve the same temperature readings on different cylinders. This would disturb the balance in cylinder outputs.</p>
--	---

The only parameter relevant for adjusting the same power output on all cylinder units - provided injection cam positions are correct - is the fuel rack position.

Regularly monitor the temperatures after cylinder.

In case of deviations, identify the cause (e.g. nozzle, injection pump, exhaust valve), see ***operating instructions, chapter "Operational Disturbances" and chapter "Troubleshooting"***

8.3.2 Single-Pipe Exhaust Manifold

The single-pipe and also the pulse charging exhaust manifold causes significant temperature differences between the individual cylinders due to the firing order and the short crank angle intervals in the firing order (9-cylinder: 80° crank angle, 6-cylinder: 120° crank angle).

Nevertheless, gas exchange and scavenging of all cylinders are trouble-free and each cylinder gets the full amount of charge air when the inlet valves are closing.

This is the reason why thermal load in terms of valve temperature is nevertheless even and does not show such big discrepancies as the exhaust temperatures.

8.3.3 Permissible Exhaust Temperatures

The exhaust temperatures at 100 % load should not exceed the values in the acceptance test record (see *engine documentation, chapter "Technical Data"*) by more than the following values:

After cylinder:	+70 °C*	max. 530 °C
Before turbine:	+50 °C	max. 570 °C
After turbine:	+50 °C**	max. 530 °C

Example:

texh7	=	436 °C + 70 °C = 506 °C
texh8	=	381 °C + 70 °C = 451 °C
tbefT	=	477 °C + 50 °C = 527 °C
taftT	=	289 °C + 50 °C = 339 °C

* = difference between the cylinders: $t_{max} - t_{min} < 120 \text{ °C}$

** = At part load the temperature should not exceed 530 °C

- If any limits are exceeded, identify the cause of the temperature increase such as deviating ambient conditions, fuel grade, contaminated turbocharger or similar, see *operating instructions, chapter "Operational Disturbances" and chapter "Troubleshooting"*.
- Reduce the engine power if maximum permissible temperatures are exceeded during operation.
- Carry out an additional check regarding combustion by evaluating exhaust gas opacity. When the combustion is good, the exhaust gas will be invisible to light grey. For evaluation of the exhaust gas colour see *operating instructions, chapter "Operational Disturbances" and chapter "Troubleshooting"*.

	NOTE
	<p>Note for exhaust temperature monitoring devices</p> <p>An alarm by an exhaust temperature monitoring device may be attributable to operational misfire.</p>

	CAUTION
	<p>Property damage due to operational misfire.</p> <p>Please note that already misfire will subject the flexible coupling to impermissible load, see <i>operating instructions, chapter "Emergency Operation", paragraph "Operational Misfire"</i>.</p>

8.3.4 Firing Pressure

- Maximum permissible firing pressure (p_z) see acceptance test record (see **engine documentation, chapter "Technical Data"**).
- Permissible deviation from cylinder to cylinder according to Caterpillar/MaK ± 5 bar.
- Cylinder pressure measurement deviation/correction:

The pressure measured by the indicator valve is approximately the same as in the combustion chamber

$$p_{ind} = p_{comb.chamber}$$

8.3.5 Firing Pressure Indication

	NOTE
	<p>When indicating make sure engine load is constant during the measurements</p> <p>Upon assembly the screwed connection between indicator and indicator valve must be gas tight.</p> <p>A finger-tight, positive and non-positive fit must be reached.</p>

Use the following electronic indicator for pressure measurement:

- Lemag PREMETS LS

This is a good method to identify changes in the firing pressure of individual cylinders. Indication is necessary when the assessment of the exhaust temperatures suggests that there are changes in individual cylinders. Even if no irregularities are identified by the exhaust temperature monitoring, it is advisable to check the engine at regular intervals by means of indication.

Only perfect measuring instruments will provide accurate measurement results. Store the measuring instrument with care and observe the manufacturer's instructions.

- Operating instructions for the indicator see **operation instructions, chapter "External Documentation"** in the Premet box.
- Draw indicator diagrams at full load if possible.
- Blow out the indicator valves so that no combustion residues can enter the measuring instrument.

Indicating

	NOTE
	<p>Close the indicator valve completely after the indication process. Loosen the connection when there is no pressure at the indicator any more.</p>

Note the following on the diagram: date, engine number, cylinder number, exhaust temperature after cylinder, fuel rack position, engine speed, charge air pressure.

	NOTE
	<p>It is not allowable to correct the firing pressure by changing a correctly adjusted commencement of fuel delivery. This will affect the cylinder power.</p>

8.3.6 Turbocharger: Compressor/ Turbine Cleaning

During operation fine sticky dust is deposited on the inner air carrying parts of the compressor which can significantly reduce the performance of the compressor. For cleaning the compressor please refer to the turbocharger operating instructions in book C.

- Daily cleaning of the compressor
- Periodical washing of the turbocharger when operating on heavy fuel, see *operating instructions A5.05.06.05.00.nn*.

8.3.7 Charge Air Cooler

- Check the condensate drain of the charge air duct every 24 hours (daily).

8.4 Turbocharger: Compressor Side

8.4.1 Foreword

Contamination of the compressor stage (impeller and diffuser) depends on the degree of cleanliness of the intake air and the operating point.

Dirt will deposit in the air ducts particularly when oil or salt mists or various types of dust are taken in from the engine room or from outside.

Contamination of the compressor stage has a detrimental effect on compressor efficiency and charge air pressure and leads to increased exhaust temperatures on engine side, increased fuel consumption, and a possible rotor unbalance.

	<p style="text-align: center;">NOTE</p> <p>Periodic cleaning (see engine documentation, chapter „Maintenance“, job card A5.05.06.05.00.nn) of the compressor during operation will prevent or delay an excessive increase in contamination, but is by no means a substitute for the maintenance work involving a complete dismantling of the turbocharger.</p>
---	--

8.4.2 Cleaning Principle

For cleaning the compressor stage during operation water is injected before the impeller by means of an injection tube in the air filter silencer.

	NOTE
	Compressor cleaning is most effective when the engine is operated at full load.

Water will not act as a solvent in this case. Deposits will be removed by the mechanical impact of the water droplets. This method is appropriate as long as contamination has not progressed too far.

A metering container is installed on the engine which is used for turbocharger washing.

The following procedure is used for washing:

The surface of the water in the washing water container is pressurized with air from the charge air duct. Driven by the charge air pressure, the washing water will flow to the turbocharger to be cleaned when the valve on the washing water container is actuated.

	⚠ CAUTION
	<p>Personal injury due to squirting liquid.</p> <p>Opening or filling the washing water container when one or more valves are open may cause injuries to the operator.</p> <ul style="list-style-type: none"> > Keep all valves in the air side turbine washing system closed (basic position).

Please refer to **engine documentation, chapter „Maintenance“, job card A5.05.06.05.00.nn** for the operating procedure of the cleaning device.

	NOTE
	A thick layer of encrusted deposits can only be removed from the compressor after the latter has been dismantled. Therefore, frequent cleaning of the compressor during operation is recommended for machines with increased dust, oil, or salt mist exposure.

	CAUTION
	<p>Property damage due to corrosion.</p> <ul style="list-style-type: none"> > Only use clear water (drinking water). > Never use salt water. > Do not add any cooling water additives or other chemicals which may form deposits in the flow ducts.

The injection tube must never be connected directly to city water, to a different or larger metering container (larger water container).

The only authorized configuration is the original configuration provided by Caterpillar Motoren GmbH & Co. KG.

	NOTE
	<p>The time between cleaning intervals depends primarily on the operating conditions. Cleaning should be performed daily or every 24 to 100 operating hours (<i>see engine documentation, chapter „Maintenance“, job card A5.05.06.05.00.nn</i>).</p>

8.4.3 Compressor Side - Turbocharger Cleaning Parameters

Cleaning parameters see *engine documentation, chapter „Maintenance“, job card A5.05.06.05.00.nn.*

After the water injection time reset the washing device to basic position and check whether the water volume that was filled in has been injected completely.

	⚠ CAUTION
	<p>Personal injury and damage to property due to the ingress of water into turbocharger and engine.</p> <p>An uncontrolled ingress of water into turbocharger and engine may cause personal injury and damage to property.</p> <ul style="list-style-type: none"> > Make sure that water cannot get into turbocharger and engine in an uncontrolled manner.

The capacity of the water container is designed for cleaning one turbocharger.

8.5 Changing the Type of Fuel

Regardless of the type of fuel the chapters "*Instructions for Heavy Fuel Operation*" and "*Commissioning*" of the operating instructions are to be taken into account. All data in the text referring to the elements of the legend (HPR3, HH1, etc.) refer to the fuel systems suggested by Caterpillar in chapter "*Instructions for Heavy Fuel Operation*". You may find your current fuel system design to be different from these.

A changeover from heavy fuel to distillate fuel takes place before maintenance work on the injection system and is expressly recommended before such work. A changeover may also become necessary to comply with legal emission regulations in specific trading areas and in case of longer operation at low load.

8.5.1 Changeover from Distillate Fuel to Heavy Fuel

Make the necessary preparations according to *operating instructions, chapter "Commissioning"*.

For the above-mentioned reasons we recommend to carry out the changeover at part load (<75 % engine load) only. During the changeover process the filter lifetimes may be considerably reduced due to the precipitation of asphaltenes.

8.5.2 Changeover from Heavy Fuel to Distillate Fuel

In order to avoid undue prolonging of the changeover procedure, we recommend to carry out the changeover at engine loads >50 %. During the changeover process the filter lifetimes may be considerably reduced due to the precipitation of asphaltenes.

A timely changeover is required, because depending on the engine load the changeover to distillate fuel will only be completed after **1/2 - 1 h** .

The changeover has to be **exclusively** made by means of the three-way cock (valve HR6) for selecting heavy fuel/distillate fuel. The three-way cock (valve HR7) in the return line (from the engine to the heavy fuel day tank or mixing tank) **must remain** in its position so that the excess fuel will be returned to the circuit.

Circulating pumps HP3, HP4, the heavy fuel final preheater and, if provided, the standby final preheater HH2 are to be switched off earliest 1 h after the changeover.

	NOTE
	<p>In order to achieve a quicker draining of the system filled with heavy fuel the following emergency changeover is possible: By means of the three-way cock (valve HR6) change over to distillate fuel from the diesel oil day tank DT1 (admission) and by means of the three-way cock (valve HR7) change over directly to the heavy fuel day tank HT1 (return) and flush the system with distillate fuel.</p> <p>This emergency changeover is only permitted when the engine is shut down!</p>

	⚠ WARNING
	<p>There is a probability of increased component wear due to a longer changeover to distillate fuel.</p> <p>An engine designed for operation on heavy fuel (HFO) may also be operated on distillate fuel (MDO) for a short time. However, if such an engine is operated for a continuous period of more than 750 hours on distillate fuel, this may lead to increased component wear.</p> <p>> If operating times of more than 750 hours on distillate fuel are planned, please contact the customer service of Caterpillar beforehand.</p>

	NOTE
	<p>Fuel pressure system (within the heavy fuel circuit only):</p> <p>The fuel pressure may only be adjusted on the pressure control valve before mixing tank.</p>

8.6 Lubricating Oil System

- Daily check of the level in the
 - Lubricating oil sump tank,
 - Base frame,
 - Oil pan.
- Monitoring of lubricating oil pressure and temperatures.

See pressure and temperature data as well as the acceptance test record in the **engine documentation, chapter "Technical Operating Data"**.

8.7 Cooling Water System

- Check of the level in the freshwater expansion tank.
- Monitoring of cooling water pressure, cooling water temperatures, and temperature rise.

See pressures and temperatures of the operating media as well as the acceptance test record in the ***engine documentation, chapter "Technical Operating Data"***.

If the operating temperatures are too high, slowly decrease them until normal operating values are reached.

Regulations and maintenance of the engine cooling water see ***engine documentation, chapter "Operating Media", paragraph "Cooling Water"***.

8.7.1 Adjustment Instructions for Cooling Water Pressure (Start of Standby Pump, Alarm, and Emergency Stop)

	NOTE
<p>There must be a minimum cooling water pressure of 2.5 bar at the engine in order to safely dissipate from the engine the amount of heat generated under full load operation.</p>	

Terminal temperature difference

Under full load operation the cooling water will be heated up by 7 to 10 K to a max. outlet temperature of 90 °C (temperature difference between cooling water distributing-and collecting pipe). The engine should be run at full load for at least half an hour so that the temperature in the entire cooling system can reach a steady state.

If these temperature values are not reached, **contact the dealer**.

The alarm chain is as follows:

Minimum operating pressure*	2.5 bar
Start of standby HT freshwater pump	2.3 bar
Low HT freshwater pressure at engine inlet – Alarm 2102	2.1 bar
Low HT freshwater pressure at engine inlet – Emergency stop 2103	1.9 bar

If the cooling water pressure in the cooling water system is 0.2 bar below the minimum cooling water pressure, a standby pump will be started. If the cooling water pressure drops by another 0.2 bar, an alarm will be triggered. If the pressure in the cooling water system continues to drop down to 1.9 bar, an emergency stop will be triggered.

*These values do not take into account the static pressure of the freshwater expansion tank. In the following examples static pressure will be considered.

1. example - Controllable pitch propeller plant with two electric standby pumps

The HT freshwater expansion tank is full of cooling water and both electric standby pumps are switched off. The pressure indicator for HT freshwater on the engine control stand displays the static pressure for HT freshwater.

This static pressure is to be added to the operating pressure.

Example: Static pressure at engine control stand is 1 bar (both electric pumps switched off).

This results in a **minimum operating pressure of 3.5 bar**.

Adjust and check the following values:

Minimum operating pressure (add static pressure)	3.5 bar
Start of standby HT freshwater pump	3.3 bar
Low HT freshwater pressure at engine inlet – Alarm 2102	3.1 bar
Low HT freshwater pressure at engine inlet – Emergency stop 2103	2.9 bar

	NOTE
<p>For sensor equipment adjustment and test instructions please refer to the manual. Under full load operation the cooling water will be heated up by 7 to 10 K to a max. outlet temperature of 90 °C.</p>	

2. example - Generator plants with attached and electric cooling water pump and controllable pitch propeller plants

The HT freshwater expansion tank is full of cooling water, the electric standby pump and the engine are switched off. The pressure indicator for HT freshwater on the engine control stand displays the static pressure.

This static pressure is to be added to the operating pressure.

Example: Static pressure at engine control stand is 2 bar (electric standby pump switched off).

This results in an **operating pressure of 4.5 bar at rated speed.**

Adjust and check the following values:

Minimum operating pressure at 70% (including static pressure)	3.5 bar
Start of standby HT freshwater pump	3.3 bar
Low HT freshwater pressure at engine inlet – Alarm 2102	3.1 bar
Low HT freshwater pressure at engine inlet – Emergency stop 2103	2.9 bar

Adjustment at rated speed

The engine is running at rated speed and the electric standby pump is switched off. The pressure indicator for HT freshwater on the engine control stand displays an operating pressure of min. 4.5 bar.

	NOTE
At rated speed the attached cooling water pump must generate an operating differential pressure of 2.5 bar.	

Adjustment at 70 % rated speed

The engine is running at 70 % rated speed and the electric standby pump is switched off. The pressure indicator for HT freshwater on the engine control stand displays an operating pressure of min. 3.5 bar.

At 70 % rated speed the attached cooling water pump must generate an operating differential pressure of 1.5 bar.

Switch off the entire cooling water pressure monitoring system below 70 % rated speed.

	<p style="text-align: center;">NOTE</p> <p>The electric standby pump shall only intervene in the event of a failure of the attached pump</p>
---	---

The cooling water circuit is monitored for cooling water temperature over the entire speed range. Cooling water temperature monitoring must not be disabled.

For sensor equipment adjustment and test instructions please refer to the manual (see ***operating instructions, chapter "Maintenance"***). Under full load operation the cooling water will be heated up by 7 to 10 K to a max. outlet temperature of 90 °C.

8.8 Starting Air System

The compressed air for starting the engines is to be supplied to the engines in clean and dry condition. The applicable guideline is ISO 8573-1 Class 4, the pressure dew point is to be about 25 °C ambient temperature so that the maximum water content may be 22 g / m³.

- Check the air pressure in the air receivers.
- Daily drain the air receivers, compressed air filters, water separators, and valves with drain devices or provide for automatic draining.
- Ensure compressed air supply to the emergency stop device.



NOTE

Do not close the shut-off valve for starting air during operation of the engine (see *operating instructions, chapter "Commissioning", paragraph "Starting Air System"*).

9 Resumption of Engine Operation after a Short Interval

- Make sure that the engine is preheated before starting. If necessary, use the preheating device.
- Switch on the lubricating oil pump
- Switch cooling water pumps to "automatic operation"
- Open the starting air receivers
- Set emergency stop lever (**10**) to vertical starting position
- If necessary, carry out a "RESET" on the safety system
- Start the engine
- Once there is sufficient cooling water and lubricating oil temperature the engine can be loaded.

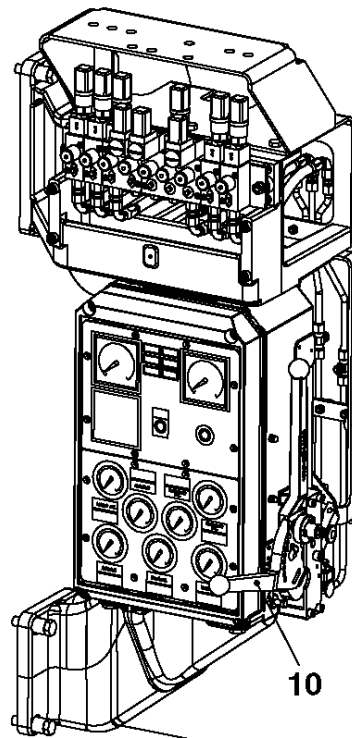

10 Operational Disturbances

10.1 Operational Disturbances - General

If any irregularity should occur within the engine plant, the fault is to be located based on the characteristics of the respective disturbance and the cause is to be identified. Immediate actions are to be taken to remedy the disturbances.

	<h3>CAUTION</h3>
	<p>Damage due to engine disturbances.</p> <p>Disturbances of the engine may cause significant damage to property.</p> <ul style="list-style-type: none"> > If any disturbances are recognized, always shut down the engine in a timely manner to prevent any consequential damage. > It is by no means allowable to ignore minor disturbances whose cause is not obvious or whose impact on operation is currently of minor importance. Such disturbances must be remedied as soon as possible.

Depending on the kind of incidence it has to be decided whether and how much to decrease power output and speed respectively during the failure period.

In case of a failure of measuring instruments or monitoring devices that cannot be replaced immediately, engine operation is to be continued with particular attentiveness and care, especially when the failure has affected an alarm and/or safety system.

If a corresponding level of automation is provided, the alarm and safety system displays all essential faulty deviations.

For disturbances in the remote control systems or certain attached devices such as governor or turbocharger, etc. please also refer to the corresponding paragraphs in the **engine documentation, chapter "External Documentation"**.

If in case of an engine damage no immediate repair is intended, it is necessary, depending on the expected time of repair, to carry out an engine preservation according to the **operating instructions, chapter "Storage and Preservation" and paragraph "Light Preservation" and "Heavy-Duty Preservation"**.

10.2 Emergency Stop Safety Devices

	⚠ DANGER
	<p>Emergency Stop Safety Devices</p> <p>Failure to comply with the following may lead to severe personal injuries and engine damage and cause the warranty agreements to be void.</p> <ul style="list-style-type: none"> > For the time being no more starting attempts are allowed. > The following items and measures absolutely have to be complied with and addressed.

	NOTE
	<p>With some engine plants, particularly in marine applications, an alarm or a power reduction may be triggered before a safety emergency stop takes place. If there are no safety concerns, the engine must also be stopped in case of an alarm or an engine power reduction and the causes have to be eliminated.</p>

10.2.1 Actions that Must be Performed after a Safety Emergency Stop*:

- Identify the reason for the emergency stop based on the items listed below.
- Address the corresponding sub-items.
- Contact the Caterpillar Customer Service Support.

10.2.2 Type of Emergency Stop:

1. Overspeed
2. Lubricating oil (pressure and temperature)
3. Crankcase monitoring
4. Cooling water, HT freshwater (pressure and temperature)
5. Exhaust gas
6. Check the pneumatic emergency stop system on the engine after every emergency stop
7. Fault messages and measuring points

	NOTE
	<p>The checks indicated below are intended to assist in troubleshooting and will allow to identify the main causes of an emergency stop. However, they cannot cover the full range of all possible causes.</p>

10.2.2.1 Overspeed

- **Emergency stop due to excessive engine speed**

What was the maximum speed before the emergency stop was triggered?

Why did the engine run at overspeed?

Check:

- Check whether the emergency stop safety device is in operation.
- Check the control shaft with related linkage for ease of movement.
- Check each individual control rod of the fuel pumps for proper function by pulling/pressing them into both directions.
- Check the governor drive
- Check the actuator (if provided) for possible decalibration.

Contact the Caterpillar Customer Service Support.

10.2.2.2 Lubricating Oil (Pressure, Temperature)

- **Emergency stop due to lack in lubricating oil**

Check:

- Carry out a visual inspection of the main running gear
- Lubricating oil pump drive:
 - Check the gear wheels for damage or loss.
- Check the lubricating oil pressure switches.
- Check the lubricating oil filter for metal chips.
- Check the oil pan and piping for leaks and cracks.

Contact the Caterpillar Customer Service Support.

- **Emergency stop due to excessive lubricating oil temperature**

Check:

- Check the temperature sensor.
- Check the oil cooler.
- Check the cooling water circuit.
- Admit compressed air to each cylinder via the opened indicator valves.
If the pressure drops very quickly or no pressure builds up, the cause of this must be identified.

Contact the Caterpillar Customer Service Support.

10.2.2.3 Crankcase Monitoring

- **Emergency stop due to excessive oil mist concentration (see *operating instructions, chapter "Operational Disturbances", paragraph "Oil Mist Alarm"*).**

Check:

- Check the crankcase monitoring device (functional test), see manufacturer documentation in *operating instructions, chapter "External Documentation"*.
- Carry out a visual inspection of the main running gear and timing gear.
- Carry out a visual inspection of the camshaft casing.
- Carry out a visual inspection of the combustion chamber.
- Carry out a visual inspection of the turbocharger.

Contact the Caterpillar Customer Service Support.

10.2.2.4 Cooling Water (HT Freshwater, Pressure and Temperature)

- **Emergency stop due to excessive cooling water temperature**

Check:

- Carry out a visual inspection of the main running gear
- Check the temperature sensor.
- Check the freshwater cooler.
- Carry out a functional test of the LT cooling water circuit with cooling water pump.

Contact the Caterpillar Customer Service Support.

10.2.2.5 Exhaust Gas

- **Emergency stop due to excessive exhaust temperature**

Check:

- Check the exhaust temperature sensors.
- Charge air cooler (differential pressure) (see *engine documentation, chapter "Maintenance", job card A5.05.06.04.02.nn*).
- Fuel pumps and fuel rack scale of each fuel pump.
- Injection nozzles (see *engine documentation, chapter "Maintenance", job card A5.05.07.08.01.nn*).
- Turbocharger.

Contact the Caterpillar Customer Service Support.

10.2.2.6 Check the Pneumatic Emergency Stop System on the Engine after every Emergency Stop

	CAUTION
	<p>Property damage if the emergency stop safety device is not working properly</p> <p>The emergency stop safety device must be working properly at all times to prevent damage to property and major hazards.</p> <p>> As a prerequisite for proper function of the emergency stop safety device supply with compressed air of 7.5 bar must be ensured at all times.</p>

Check:

- Check the pneumatic emergency stop system on the engine for leaks.
- The shut-off valve to the main starting air pipe before starting air must always be open during operation (see **operating instructions, chapter "Commissioning", paragraph "Starting Air System"**).

10.2.2.7 Fault Messages and Measuring Points

	NOTE
	<p>The fault messages listed below do not directly lead to an emergency stop, but they considerably affect reliable engine operation.</p> <p>If such a fault message appears on the monitoring display of the alarm system, the engine plant may only be operated for a short time and under permanent observation.</p> <p>At any rate, the cause of the fault message must be remedied immediately.</p>

General fault messages:

Fault Message (Designation of Measuring point)	Description:
6105 *	Low shutdown air pressure
9631 *	Oil mist detector failure
9601 *	Terminal set X1 voltage failure
9717 *	Terminal set X3 voltage failure

* see also list of measuring points in the *engine documentation, chapter "Control/Regulation"*

Plant-specific fault messages:

- Safety system failure
- RPM switch unit failure (overspeed)

Contact the Caterpillar Customer Service Support.

10.3 Oil Mist Alarm

The crankcase monitoring device (oil mist detector) monitors the oil mist concentration in the crankcase. During engine operation there is always a slight oil mist concentration. If, however, the actual oil mist concentration exceeds a preset, fixed value first an alarm and then, in case of a further increase in concentration, an automatic engine stop will be triggered. An increased oil mist concentration in the crankcase may be indicative of operational disturbances, with bearing damages, timing gear train damages, piston seizure or blow-by from the combustion chamber being the most frequent causes.

	⚠ DANGER
	<p>Risk of explosion.</p> <p>With increased oil mist concentration there is a risk of crankcase explosion. This may lead to severe personal injuries and engine damage.</p> <ul style="list-style-type: none"> > Stop the engine immediately. > Arrange warning notices on the protective covers closing the inspection openings in the engine block. > Before opening the protective covers wait at least 20 minutes until the engine has cooled down. > When an alarm is triggered, the underlying cause must be identified. > Do not restart an engine that has run hot without first eliminating the cause.

10.3.1 Checks after an engine stop due to oil mist alarm

Check of the oil mist detector:

Check the oil mist detector for correct function according to the documentation of the manufacturer (see *operating instructions, chapter "External Documentation"*).

i	NOTE
	<p>Besides carrying out a normal functional check of the oil mist detector the measuring chamber should be examined for traces of water. Water vapour may trigger a false alarm. If there are any traces of water, the measuring chamber and the sensors must be cleaned.</p>

Check of the main running gear:

- Remove all crankcase doors.
- Check the main running gear for ease of movement by turning the crankshaft.
- Carry out a visual inspection of the main running gear (bearings, piston skirts, cylinder liners, etc.) for discoloration and seizing marks.
- Measure all bearing temperatures, pay particular attention to major discrepancies.
- Check the oil pan for chips.
- Check the lubrication oil filters for metallic debris.

Check of the timing gear train:

- Remove all inspection doors from both sides.
- Carry out a visual inspection of the timing gear train for discoloration, seizing marks, and chips.
- Carry out a visual inspection of the drives of all attached pumps.

Check of the camshaft casing:

- Remove all camshaft casing covers.
- Carry out a visual inspection of camshaft, cam followers and rollers of all valve and injection pump drives for discoloration, wear (seizing), and chips.
- Measure the temperatures of all camshaft bearings.

Check of the combustion chamber:

- Admit compressed air to each cylinder via the opened indicator valves. If the pressure drops very quickly or no pressure builds up, the cause of this must be identified.

Check of the turbocharger:

	<p style="text-align: center;">NOTE</p> <p>An incipient turbine bearing damage will also be indicated via the oil mist detector.</p>
---	---

- Remove intake air filter.
- Check the turbine shaft for ease of movement.
- Check the operating parameters.

	⚠ DANGER
	<p>It is absolutely required to complete all of the checks.</p> <p>Only after having completed all the above checks and if no failure causes have been identified the engine may be restarted.</p> <ul style="list-style-type: none"> > Prior to starting the engine is to be turned through and purged sufficiently with open indicator valves by means of starting air. > While doing so, check the indicator valves for emerging oil, fuel or water. The engine may then only be started with fully functional oil mist detector. <p>If an emergency stop should occur again after a short time, the root cause must absolutely be found out. The engine must not be restarted until the disturbance or damage has been eliminated.</p>

Contact the Caterpillar Customer Service Support.

	NOTE
	<p>The indicated checks are intended to assist in troubleshooting and will allow to identify the main causes of an oil mist alarm. However, they cannot cover the full range of all possible causes.</p>

11 Troubleshooting

11.1 Safety Notes

11.1.1 Personal Prerequisites

Troubleshooting may only be carried out by persons who

- due to their education and qualification, are authorized to do so
- have been commissioned to do so by the operator of the engine.

Work on the pneumatic and hydraulic equipment may only be carried out by specifically trained personnel possessing the relevant specialist knowledge and experience.

	<p>⚠ DANGER</p>
<p>Risk of explosion.</p> <p>In the engine block oil mist is forming. At high temperatures in combination with oxygen from the ambient air this may lead to explosion.</p> <ul style="list-style-type: none"> > Before opening the protective covers on the inspection openings in the engine block wait 20 minutes until the engine has cooled down. > Observe the warning notices. 	

	<p>⚠ CAUTION</p>
<p>Personal injury due to hot surfaces.</p> <p>When carrying out work on the engine there is a risk of burns.</p> <ul style="list-style-type: none"> > Do not touch hot surfaces and parts. > Before start of work allow hot surfaces and parts to cool down. > Observe the temperature indicators. 	

	⚠ CAUTION
	<p>Personal injury due to components under pressure.</p> <p>Components under pressure may cause severe injuries when handled improperly.</p> <ul style="list-style-type: none"> > Observe the pressure indicators. > Depressurize all components before starting to work.

	⚠ CAUTION
	<p>Personal injury and damage to property due to highly inflammable operating media.</p> <p>Improper handling of inflammable/highly inflammable operating media may cause burns and property damage.</p> <ul style="list-style-type: none"> > No open light or fire when handling inflammable/highly inflammable operating media. > No smoking.

11.1.2 Preparations for Troubleshooting

- Stop the engine, switch it off and secure it to prevent restarting according to these operating instructions.
- Close off a large area where the engine is being repaired.
- Inform the operating personnel and designate a supervising person.

11.1.3 Measures before Restarting after Disturbances

- Reset the faults.
- Check the safety devices.
- Check whether the engine is performing all of its functions properly.



11.2 General Information about Troubleshooting

Heat dissipation on pumps/engines must not be affected.

In case of disturbances on peripheral devices (such as pumps, etc.) also observe the documentation of the manufacturer in the appendix to these operating instructions.

If the cause of a disturbance cannot be identified in spite of thorough investigations, contact the Caterpillar Customer Service Support.

In this case, please let us have the following data:

- Engine type
- Year of construction
- Engine number

The required data is indicated on the nameplate of the engine (see *engine documentation, chapter "Structure and Function", paragraph "Nameplate"*).

11.3 Disturbances and Troubleshooting

11.3.1 Engine does not start at all or starts poorly

Possible Cause	Remedy
Insufficient air pressure in the starting air receiver	Required pressure in the air receiver see <i>engine documentation, chapter "Technical Engine Data"</i>
Solenoid valve to the air starter (if provided) is defective	
Air starter (if provided) is defective	
Main starting air valve is defective	
Starting interlock	Check and, if necessary, reset the safety system

11.3.2 Engine reaches firing speed but does not fire

Possible Cause	Remedy
Governor does not admit fuel <ul style="list-style-type: none"> • Stop cylinders do not release fuel • Governor oil pressure is insufficient 	See manufacturer documentation in <i>operating instructions, chapter "External Documentation"</i> : Governor Failures
Linkage between governor and control shaft is defective <ul style="list-style-type: none"> • Faulty connection between governor terminal shaft and injection pump control shaft • Elastic element in the linkage of the control shaft • Control shaft sluggish, control shaft jammed, fuel admission pressure is set too high 	

Possible Cause	Remedy
Lack of fuel	
<ul style="list-style-type: none"> • Day tank is empty 	
<ul style="list-style-type: none"> • Insufficient venting of the fuel system 	Vent the system, see <i>operating instructions, chapter "Commissioning", paragraph "Fuel System"</i>
<ul style="list-style-type: none"> • Shut-off devices are not in operating position 	
<ul style="list-style-type: none"> • Fuel filters are clogged 	Clean the filters, see <i>engine documentation, chapter "Maintenance", job card <u>A5.05.07.12.01.nn</u></i>
<ul style="list-style-type: none"> • Fuel feed pump is defective 	Repair or replace the pump, see <i>engine documentation, chapter "Maintenance", job card <u>A5.05.07.13.01nn</u></i>
<ul style="list-style-type: none"> • Lubricating oil pressure switch is defective or misadjusted so that the solenoid valve switches off after the starting attempt 	
<ul style="list-style-type: none"> • Engine is too cold 	Warm up the engine, see <i>operating instructions, chapter "Commissioning", paragraph "Putting into Service / Starting"</i>

11.3.3 Fuel filter differential pressure too high during starting/prelubrication

Possible Cause	Remedy
Fuel filters are clogged	Clean the filters, see <i>engine documentation, chapter "Maintenance", job card A5.05.07.12.01.nn</i>
Differential pressure indicator is defective	
Oil is too cold	
Water in the oil causes greasy emulsion and oil thickening	
Oil cooler is leaky	

11.3.4 Engine does not reach full speed and/or power

Possible Cause	Remedy
Governor failure	See manufacturer documentation in <i>operating instructions, chapter "External Documentation"</i> : Governor Failures
Filter of charge air pressure dependent fuel limiter is clogged	
Fuel system is defective	
<ul style="list-style-type: none"> • Air in the fuel system 	
<ul style="list-style-type: none"> • Water in the fuel 	
<ul style="list-style-type: none"> • Fuel feed pump is defective 	Repair or replace the pump, see engine documentation, chapter "Maintenance", job card A5.05.07.03.01nn
<ul style="list-style-type: none"> • Fuel filters are clogged 	Clean the filters, see engine documentation, chapter "Maintenance", job card A5.05.07.12.01.nn
<ul style="list-style-type: none"> • Delivery valve of the injection pump is damaged 	
<ul style="list-style-type: none"> • Pump element has seized 	
<ul style="list-style-type: none"> • Nozzle is clogged, nozzle needle has seized 	Service the injection elements, see engine documentation, chapter "Maintenance", job card A5.05.07.03.01nn

Possible Cause	Remedy
Engine does not get enough air	
<ul style="list-style-type: none"> • Intake air filter is clogged 	See manufacturer documentation in <i>operating instructions, chapter "External Documentation"</i> : Cleaning
<ul style="list-style-type: none"> • Air intake duct is obstructed 	
<ul style="list-style-type: none"> • Charge air cooler is fouled 	Clean the charge air cooler, see <i>engine documentation, chapter "Maintenance", job card A5.05.06.04.02.nn</i>
<ul style="list-style-type: none"> • Turbocharger is damaged 	Repair see manufacturer documentation in <i>operating instructions, chapter "External Documentation"</i>
<ul style="list-style-type: none"> • Turbocharger is fouled 	Repair of the compressor side or turbine side see manufacturer documentation in <i>operating instructions, chapter "External Documentation"</i>

11.3.5 Engine speed is not steady

Possible Cause	Remedy
Too much clearance in the linkage between governor and injection pump	
Fuel rack linkage is sluggish	
Friction in the injection pumps due to excessive fuel admission pressure	
Injection pump plunger is temporarily sticking, leaky or the spring is broken	
Vibration damper is defective	Check the vibration damper
Rough drive due to wear and tear or damaged teeth	
Governor failure	See manufacturer documentation in <i>operating instructions, chapter "External Documentation"</i> : Governor Failures

11.3.6 Opaque exhaust gas - engine is emitting soot

Possible Cause	Remedy
Opening pressure of the injection nozzle is insufficient	
Nozzles are coked	
Jammed nozzle needle or nozzle is defective	
Lack of air	
<ul style="list-style-type: none"> • Intake air filter is clogged 	
<ul style="list-style-type: none"> • Charge air cooler is fouled 	
<ul style="list-style-type: none"> • Turbocharger is damaged 	
<ul style="list-style-type: none"> • Turbocharger is fouled 	
<ul style="list-style-type: none"> • Engine is lugged down too much 	Reduce fuel supply
<ul style="list-style-type: none"> • Exhaust gas back pressure is too high because the exhaust duct is clogged 	
<ul style="list-style-type: none"> • Valves are leaky 	Repair the valves, see engine documentation, chapter "Maintenance:", job card <u>A5.05.01.08.01nn</u>
<ul style="list-style-type: none"> • Incomplete combustion due to very low load, especially when operating on heavy fuel 	Increase the load, change over to distillate fuel, see <i>operating instructions, chapter "Operational Monitoring", paragraph "Changing the Type of Fuel"</i>

11.3.7 Exhaust gas is blue

Possible Cause	Remedy
Oil in the combustion chamber	
<ul style="list-style-type: none"> • Piston rings are stuck 	Servicing of pistons and rings, see engine documentation, chapter "Maintenance", job card A5.05.02.07.01.nn
<ul style="list-style-type: none"> • Severe liner wear: Score marks, ovality 	Clean the liner, see engine documentation, chapter "Maintenance", job card A5.05.03.03.01.nn
<ul style="list-style-type: none"> • Valve guide and/or seal is worn 	Check the valve guide clearance, see engine documentation, chapter "Maintenance", job card A5.05.01.05.01.nn

11.3.8 Exhaust gas is white

Possible Cause:	Remedy:
Exhaust gas condensation due to low ambient temperatures	
Part of the fuel is unburned because the engine is too cold	Warm up the engine, see <i>operating instructions, chapter "Commissioning", paragraph "Putting into Service / Starting"</i>
Water in the fuel	
Water in the charge air duct	See <i>operating instructions, chapter "Operational Monitoring", paragraphs "Exhaust System", Charge Air Cooling</i>
Leaks in the cylinder head	Replace cooled seat inserts, see <i>engine documentation, chapter "Maintenance", job card <u>A5.05.01.08.03nn</u></i>
Cylinder head is cracked	

12 Emergency Operation

12.1 Turbocharger Failure

In marine operation a turbocharged diesel engine may have to continue to operate in spite of a turbocharger failure as a naturally aspirated engine at reduced power output.

As the valve timing of the engine is essentially adjusted to full load, the engine will, in case of a turbocharger failure (and also in the lower part load range), exhaust part of the exhaust gas into the charge air pipe and take it in again. The high proportion of exhaust gas and the missing charge air pressure only permit a reduced mean effective pressure (pme) to protect the engine against thermal overload. The fuel injection pump delivery must be reduced according to the mean effective pressure recommended below.

Determining the permissible fuel rack position specific to the engine

The relation between fuel rack position (f) and mean effective pressure (pme) is approximately linear.

To determine the permissible fuel rack position, a fuel/pme graph can be created, as shown in the example, by means of two fuel rack and pme values taken from the acceptance test record.

The values for the 100 % and 50 % output figures should be taken for this. The characteristic running through both coordinates indicates the fuel rack position for any pme value.

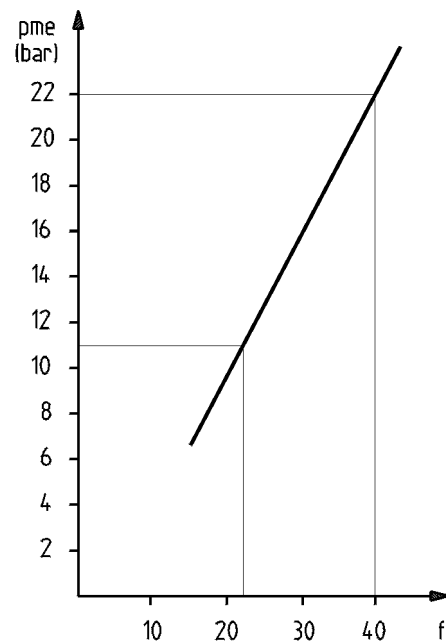

Main engine emergency operation - with dismantled turbocharger rotor

- Change over to distillate fuel, otherwise, if you continue on heavy fuel for more than 24 hrs, inspect all exhaust valves and replace them if any deposits or high-temperature corrosion should be visible (see **engine documentation, chapter "Maintenance", job card A5.05.01.08.nn**).
- Stop the engine.
- Remove the air filter silencer.
- Remove the rotor of the turbocharger, see manufacturer documentation in **operating instructions, chapter "External Documentation"**.
- Plug the air outlet on the compressor (by means of a blank flange).
- Always remove the expansion joint between air inlet casing and turbocharger.
- Plug the air inlet on the compressor.
- Interrupt the oil supply to the turbocharger, to this end:
 - Obturate the inlet side of the supply pipe by means of a plug.
 - Plug and fasten the free end of the pipe.
- Remove the cover from the free end of the charge air duct.
- Put the engine into service with reduced power output.
- Blow as much cold air as possible onto the intake openings.

With Rotor Block Dismantled We Recommend			
	Fuel rack position	% Output	kW (rpm) Output
	6 M 32		
N = const.	19	20	600 (600)
Combinator	19	18	540 (480)
	8 M 32		
N = const.	19	20	800 (600)
Combinator	19	18	720 (480)
	9 M 32		
N = const.	19	20	900 (600)
Combinator	19	18	810 (480)

Main engine emergency operation - with blocked turbocharger rotor

	NOTE
<p>Emergency operation with blocked turbocharger rotor is only permissible if it is not possible to remove the rotor.</p>	

- Change over to distillate fuel, otherwise, if you continue on heavy fuel for more than 24 hrs, inspect all exhaust valves and replace them if any deposits or high-temperature corrosion should be visible (see *engine documentation, chapter "Maintenance", job card A5.05.01.08.nn*).
- Stop the engine.
- Interrupt the oil supply to the turbocharger, to this end:
 - Obturate the inlet side of the supply pipe by means of a plug.
 - Plug and fasten the free end of the pipe.
- Remove the air filter silencer from the turbocharger.
- Put the turbocharger out of operation, to this end block the rotor of the turbocharger.
- Remove the cover from the free end of the charge air duct.
- Always remove the expansion joint between air inlet casing and turbocharger.
- Put the engine into service with reduced power output.
- Blow as much cold air as possible onto the intake openings.

CP propeller plant

Operation at rated speed is practically impossible, because the engine output that can be reached is normally lower than the propeller input at zero pitch.

Multi-engine plants with one common propeller

These are normally CP propeller plants. Disengage the engine with defective turbocharger, adjust the propeller pitch so that the engine remaining in service can be run at rated speed and continuous power. Without equipment for unbalanced engine loads it is impossible to run the defective engine at reduced output to increase the total power available, and considering the expenditure and the small gain in power this is not necessary either.

Monitoring the engine while the turbocharger is defective

Change the fuel rack position gradually until the

- exhaust temperature after turbine is **max. 500 °C**

Carefully monitor the exhaust temperatures during emergency operation, especially if exhaust gas alarms have been disabled.

Charge air temperature while the turbocharger is defective

	NOTE
	<p>If the charge air cooler has two stages, the charge air temperature is raised at part load by blocking the low-temperature circuit of the cooler, which is controlled by charge air pressure.</p>

Due to the turbocharger failure the charge air temperature should be low, but not lower than **30 ° C**. If the charge air cooler has two stages, the low-temperature circuit must, therefore, be opened by hand.

End of the emergency operation

After **emergency operation with heavy fuel** at least one cylinder head must be removed for reasons of safety in order to assess whether a general overhaul of the valves is required, (see *engine documentation, chapter "Maintenance", job card A5.05.01.08*).

12.2 Operational Misfire

This term generally denotes operation of the engine with cylinders being subjected to uneven load. This creates additional stress that will be the higher the more the gas pressure curve of a defective cylinder differs from the other cylinders.

	<h3>CAUTION</h3>
	<p>Property damage due to partial or full failure of a cylinder.</p> <p>Partial or full failure of a cylinder will always increase the stress on the engine.</p> <ul style="list-style-type: none"> > Avoid any interventions on the engine leading to a decrease in output of individual cylinders. > Any faults identified on individual cylinders must be remedied immediately.

If operational misfire is unavoidable, i.e. cannot be remedied with the tools available on board, a distinction is made between the following extreme conditions, depending on the severity of the operational disturbance:

12.2.1 Misfire

Misfire means operation with interrupted injection at any of the cylinders. Compression pressure, however, is still present at the affected cylinder.

	NOTE
<p>Operation with closed valves is only permissible if the indicator valve/ decompression valve is opened every hour for one to two minutes at lowest engine speed and output until no more oil leaks out.</p> <p>This will prevent the oil taken in during longer emergency operation through piston clearance / ring package from lifting the cylinder head.</p> <p>Connect the drain pipe to the indicator valve and a suitable oil receiver with the means available on board so that there is no risk of accident.</p>	

- Required output and speed restrictions are indicated in the torsional vibration calculation (see *engine documentatio, chapter "Technical Engine Data"*).
- Even if there are not restrictions regarding torsional vibration, check the flexible coupling for excessive heating.
- As the engine is always subject to load fluctuations, it has to be avoided that "surging" of the turbocharger occurs at any operating point.
- In case of an excessive vibration of the control rod, reduce the vibration by shifting the operating point.

12.2.2 Monitoring of the Flexible Coupling

The following instructions and restrictions are only applicable to plants with flexible coupling.

	<h3>CAUTION</h3>
	<p>Property damage due to partial or full failure of a cylinder.</p> <p>Partial or full failure of a cylinder will always increase the stress in the flexible coupling.</p> <ul style="list-style-type: none"> > Avoid any interventions on the engine leading to a decrease in output of individual cylinders. > Any faults identified on individual cylinders must be remedied immediately.

The additional stress will be the higher the less pressure is admitted to a defective cylinder. For this reason, e.g. in case of a full failure of one cylinder unit, compression should be maintained, if possible. Remove cylinder head or valve insert or the main running gear only if this is absolutely required.

If operational misfire is unavoidable, output restrictions for the entire plant may become necessary depending on the type of plant.

Notes in this respect are provided on the engine control stand or in the torsional vibration calculation. For results of the torsional vibration calculation please refer to **engine documentation, chapter "Technical Engine Data"**.

In case of doubt, please contact the manufacturer or make the following provisional arrangement:

Single-engine plants with CP propeller

- First run the engine at only **50 %** of the rated power by reducing the propeller pitch or speed.
- If the gearbox becomes noisy and/or the speed hunts, vary the speed until an acceptable condition is reached.
- Stop the engine latest after **30 min.** and touch the coupling with your hand to check it for heating.

	NOTE
	Permissible surface temperature during operational misfire approximately 60 °C.

In case of just a moderate temperature rise, the power output can be increased in steps up to max. **80 %** of the rated power, which should not be exceeded for thermal reasons.

- At this speed stage, occasionally carry out a temperature checks and visual inspections on the flexible coupling.
- Any defect should be repaired immediately. Before returning to normal operation again, the flexible coupling should be checked for damage by a specialist of the maker.

Twin-engine/generator plants

In case of a **twin-engine plant** shut down the defective engine and run the plant with the other engine alone.

In case of a **generator plant** also shut down the defective engine. If this is not possible, emergency operation can be carried out the same way as for single-engine plants with FP or CP propeller.

	NOTE
	Do not put the defective engine into service again.